

THE

# Aztec 'E'

PILOT'S OPERATING MANUAL

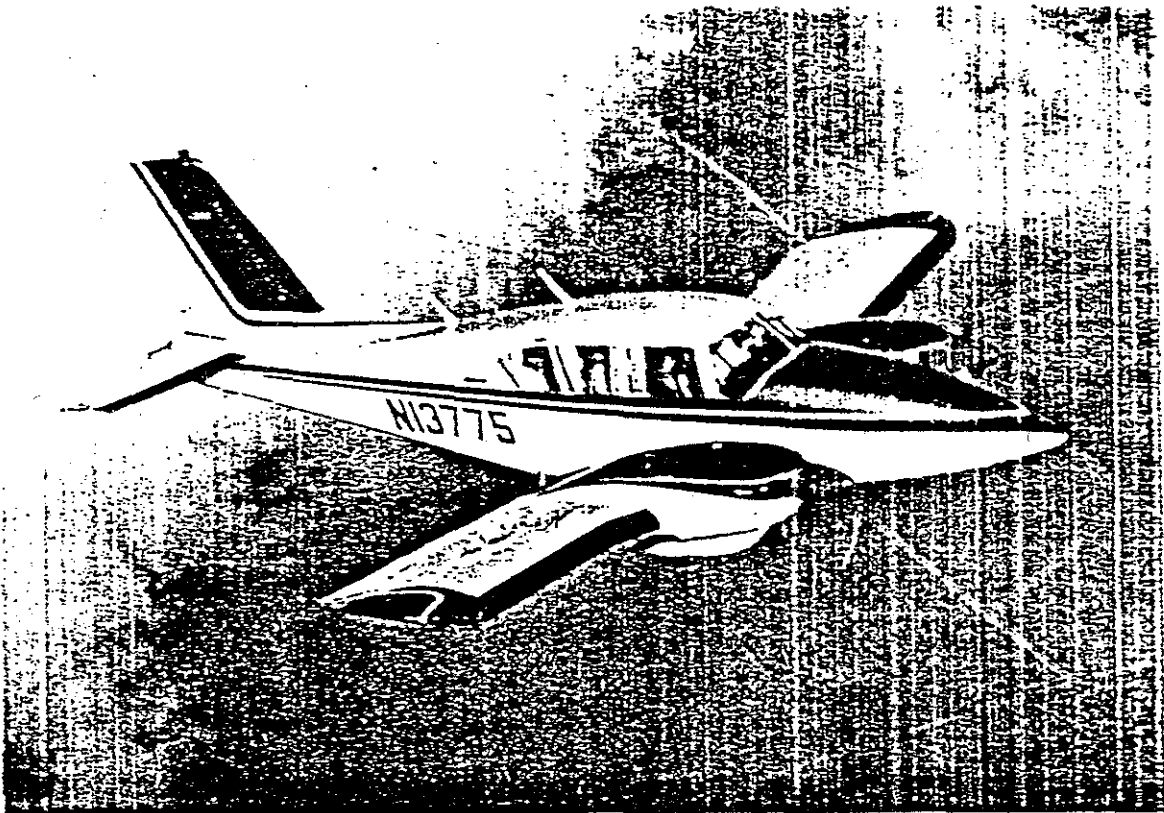

Aéro-Club St-Mathieu de Beloeil Inc.  
2025, Chemin de l'Aéroport,  
St-Mathieu de Beloeil, (Qué.)  
136 485. — 464-1151

BY

**PIPER**

This manual is incomplete without an APPROPRIATE FAA APPROVED AIRPLANE FLIGHT MANUAL and an APPROPRIATE WEIGHT AND BALANCE REPORT.

2018

Aéro-Club St-Mathieu de Beloeil  
2025, Chemin de l'Aérop.  
St-Mathieu de Beloeil, (Qué.)  
136 4S5 — 464-1161

# TABLE OF CONTENTS

- GENERAL SPECIFICATIONS
- DESCRIPTION — AIRPLANE AND SYSTEMS
- FLIGHT MANUAL FAA APPROVED
- EMERGENCY PROCEDURES FAA APPROVED
- EMERGENCY PROCEDURES
- WEIGHT AND BALANCE
- OPERATING INSTRUCTIONS
- OPERATING TIPS
- PREFORMANCE CHARTS
- HANDLING AND SERVICING

# GENERAL SPECIFICATIONS

# GENERAL SPECIFICATIONS

Performance . . . . .	1
Altitude Cruising Speeds (mph) . . . . .	1
Weights . . . . .	2
Power Plant . . . . .	2
Fuel And Oil . . . . .	2
Baggage . . . . .	3
Dimensions . . . . .	3
Landing Gear . . . . .	3

## GENERAL SPECIFICATIONS

## PERFORMANCE

Published figures are for Standard PA-23-250 airplanes flown at gross weight under standard conditions at sea level unless otherwise stated. Performance for a specific airplane may vary from published figures depending upon the equipment installed, the condition of engines, airplane and equipment, atmospheric conditions and piloting technique.

	Normally Aspirated	Turbo Charged
Take-off Run (max effort) (ft)	820	820
Take-off Distance Over 50-ft Barrier (max effort) (ft)	1250	1250
Accelerate-Stop Distance (ft)	2220	2220
Minimum Controllable Single Engine Speed (mph)/(knots)	80 (69.5)	80 (69.5)
Stalling Speed (gear down, flaps down 50°) (power off) (mph)/(knots)	70 (61)	70 (61)
Stalling Speed (gear and flaps up) (power off) (mph)/(knots)	76 (66)	76 (66)
Best Rate of Climb (ft per min)	1490	1530
Best Rate of Climb Speed (mph)/(knots)	120 (102)	115 (100)
Best Angle of Climb Speed (mph)/(knots)	107 (93)	97 (84.5)
Single Engine Rate of Climb (ft per min)	240	265
Best Single Engine Rate of Climb Speed (mph)/(knots)	102 (88.5)	104 (90)
Best Single Engine Angle of Climb Speed (mph)/(knots)	97 (84.5)	95 (82.5)
Absolute Ceiling (ft)	21,100	over 30,000
Service Ceiling (ft)	19,800	over 30,000
Single Engine Service Ceiling (ft)	5000	15,300
Single Engine Absolute Ceiling (ft)	6400	18,700
Landing Roll (Flaps down) (Max effort) (ft)	850	850
Landing Distance Over 50-ft Barrier (Flaps down) (ft)	1620	1620

## ALTITUDE CRUISING SPEEDS (MPH)

	Normally Aspirated					
	Man. Press. (in Hg)	Engine Speed (rpm)	Altitude (feet)	Speed (mph) (knots)	Range No Reserve (miles)	Fuel Con. (gph)
Normal	26	2400	4,000	210 (183)	830	34.0
Intermediate	24	2400	6,000	208 (181)	1080	27.0
Economy	24	2200	6,400	204 (177)	1110	25.0
Long Range	20	2200	10,200	195 (170)	1210	21.0

ALTITUDE CRUISING SPEEDS (MPH) (cont)

	Man. Press. (in Hg)	Engine Speed (rpm)	Altitude (feet)	Speed		Range No Reserve (miles)	Fuel Con. (gph)
				(mph)	(knots)		
				Turbo Charged TIO-540-C1A			
Turbo	34.0	2400	22,000	245	(213)	1050	32.6
Intermediate	30.0	2400	24,000	233	(203)	1125	29.0
Economy	26.0	2400	24,000	218	(190)	1175	26.0
Long Range	24.0	2200	24,000	196	(170)	1310	21.0

WEIGHTS

	Normally Aspirated	Turbo Charged
Gross Weight (lbs)	5200	5200
Maximum Landing Weight (lbs)	4940	4940
Zero Fuel Gross Weight (lbs)	4400	4500
Empty Weight (Standard, lbs)	3042	3229
USEFUL LOAD (Standard, lbs)	2158	1971

POWER PLANT

	IO-540-C4B5	TIO-540-C1A
Engine (Lycoming)		
Rated Horsepower	250	250
Rated Speed (rpm)	2575	2575
Bore (inches)	5.125	5.125
Stroke (inches)	4.375	4.375
Displacement (cu. in.)	541.5	541.5
Compression Ratio	8.5:1	7.2:1
Dry Weight (lbs)	402	490

FUEL AND OIL

Fuel Capacity (U.S. gal)	144	144
Usable Fuel		
Ser. nos. 27-4426, 27-4574 thru 27-7405476	140	140
Ser. nos. 27-7554001 and up	137	137
Fuel Aviation Grade (min octane)	91/96	100/130
Oil Capacity (qts) each Engine	12	12

	Normally Aspirated	Turbo Charged
<b>BAGGAGE</b>		
Maximum Baggage (lbs) Forward Compartment	150	150
Maximum Baggage (lbs) Rear Compartment	150	150
With oxygen installed	105	105
Baggage Space (cu ft) Forward Compartment	21.3	21.3
Baggage Space (cu ft) Rear Compartment	25.4	25.4
Baggage Door Size (in) Forward Compartment	19.5 x 30.5	19.5 x 30.5
Baggage Door Size (in) Rear Compartment	30 x 31	30 x 31
<b>DIMENSIONS</b>		
Wing Span (ft)	37.2	37.2
Wing Area (sq ft)	207.6	207.6
Length (ft)	31' 2.625"	31' 2.625"
Height (ft)	10.3	10.3
Wing Loading (lbs per sq ft)	25.05	25.05
Power Loading (lbs per hp)	10.4	10.4
Propeller Diameter (maximum, in)	77	77
<b>LANDING GEAR</b>		
Wheel Base (ft)	7.5	7.5
Wheel Tread	11.3	11.3
Tire Pressure	27	27*
	46	46
Tire Size	600 x 6	600 x 6
	700 x 6	700 x 6

\*On turbocharged Aztec "E" only with serial no. 27-4781 and subsequent, nose tire is 6.00 x 6, six ply rating and should be inflated to 32 psi.

**GENERAL SPECIFICATIONS**  
 ISSUED: September 1, 1970  
 REVISED: December 10, 1971

PAGE 3

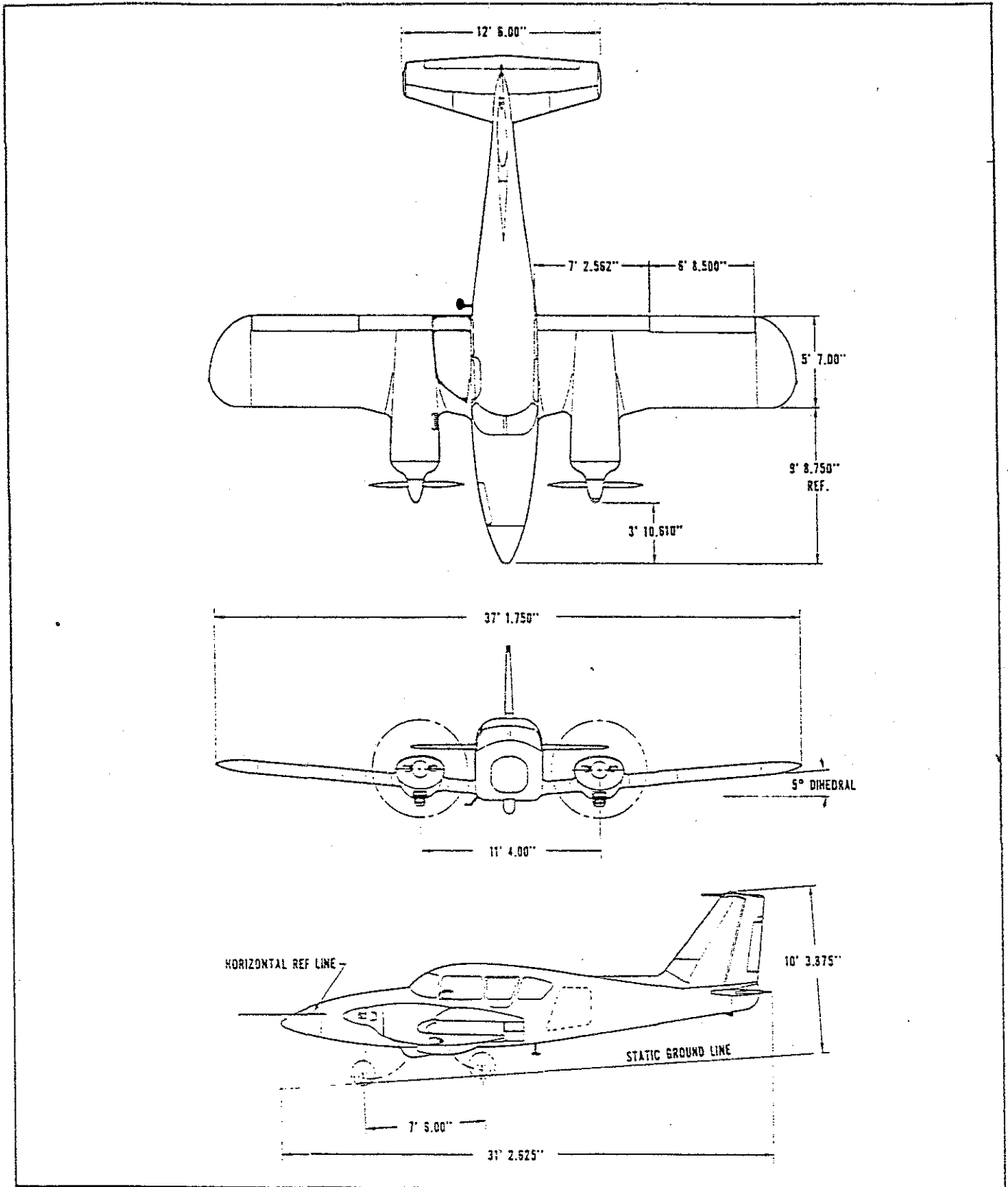



DESCRIPTION  
AIRPLANE AND SYSTEMS

DESCRIPTION  
AIRPLANE AND SYSTEMS

# DESCRIPTION

## AIRPLANE AND SYSTEMS

Engine and Accessories (Normally Aspirated) . . . . .	1
Engine and Accessories (Turbocharged) . . . . .	1
Fuel Injection . . . . .	3
Fuselage and Wing Structure . . . . .	3
Landing Gear . . . . .	4
Hydraulic System . . . . .	4
Control System and Surfaces . . . . .	6
Fuel System . . . . .	7
Electrical System . . . . .	8
Instrument Panel . . . . .	10
Heating and Ventilating System . . . . .	11
Finish . . . . .	12
Baggage Compartments . . . . .	12
Seats . . . . .	12
Cabin Features . . . . .	12
Radio Equipment . . . . .	13

## DESCRIPTION

## AIRPLANE AND SYSTEMS

## ENGINE AND ACCESSORIES (Normally Aspirated)

The Lycoming IO-540-C4B5 engines in the Aztec are rated at 250 HP at 2575 RPM. These engines have a compression ratio of 8.5:1 and use 91/96 minimum octane aviation fuel.

Both engines on the Aztec are equipped with a geared starter, alternator, vacuum pump, fuel injector, two magnetos, shielded ignition system, diaphragm fuel pump, propeller governor and an oil thermostat. The left engine is equipped with a hydraulic pump.

Engine mounts are of steel tubing construction and incorporate vibration absorbing Lord mounts. Engine cowls are cantilever structures, attached at the firewall. Side panels are quickly removable by means of quick release fasteners. The nose section is split for quick removal.

The exhaust system is a crossover type with exhaust gases directed outboard at the bottom of the nacelles in the area of the cowl flaps. The cowl flaps, located on the bottom of the engine nacelles provide additional cooling for ground operation or high temperature conditions. They are manually operated by push-pull controls located in the cabin, on the fuel control panel located between the front seats.

An efficient aluminum oil cooler is mounted on a rear baffle of each engine. Engine oil drainage is accomplished with quick oil drain valves located on the inboard rear corner of the engine crankcases.

The "Compact" propellers on the Aztec are Hartzell constant speed, full-feathering units which represent new concepts in basic design. They combine low weight with simplicity in design and are controlled entirely by use of the propeller control levers located in the center of the control quadrant. Feathering of the propellers is accomplished by moving the controls fully aft through the low RPM detent into the feathering position. Feathering takes approximately three to ten seconds. A propeller is unfeathered by moving the prop control ahead and engaging the starter. Loss of engine oil pressure will also result in propeller feathering.

## ENGINE AND ACCESSORIES (Turbocharged)

The Lycoming TIO-540-C1A engines in the Turbo-Aztec are rated at 250 HP at 2575 RPM. These engines have a compression ratio of 7.2:1 and use 100/130 minimum octane aviation fuel. The special Inconel exhaust valves and high temperature - high altitude shielded ignition harness allow continued operation at high manifold pressure without decreasing overhaul time or engine life. Internal piston cooling is accomplished by injecting oil into the piston interior.

Each of the engines on the Aztec is equipped with TEO 659 turbochargers. The turbocharger is designed to increase the power output and efficiency of the engine by supplying compressed air to the engine intake manifold. This allows the engines to operate at peak power at a much higher altitude than normally aspirated engines. The power to drive the turbocharger is extracted from energy in the exhaust gas. The exhaust gases are ducted through the turbine and then directed overboard at the bottom of the nacelles in the area of the cowl flaps.

The cowl flaps, located on the bottom of the engine nacelles, provide cooling for ground operation or high temperature at low airspeed-high power conditions. They are manually operated by push-pull controls located in the cabin on the fuel control panel between the front seats. For multi-engine operation maximum cowl flap position is half open. Single engine operation requires fully open flap on operative engine.

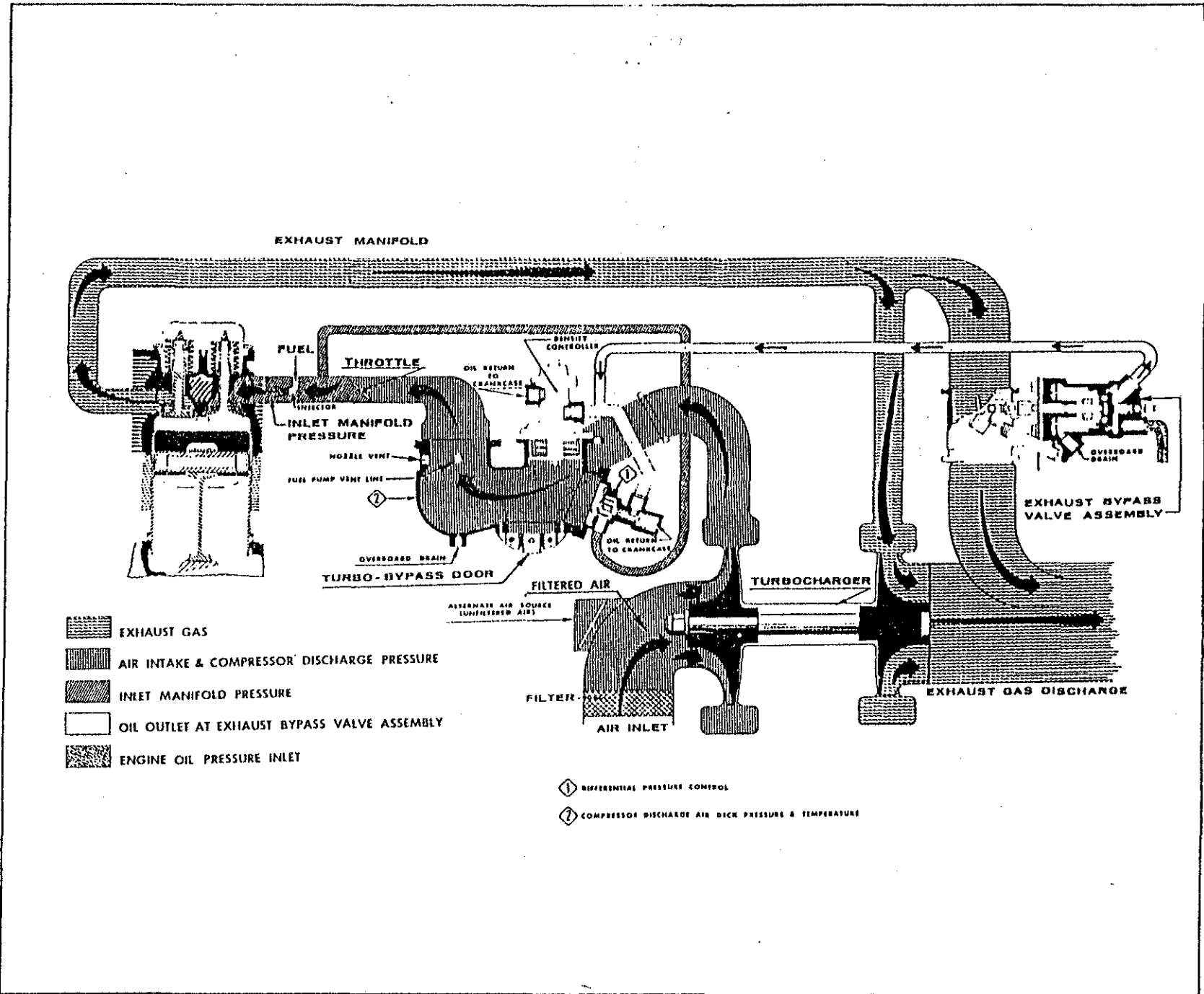

Turbo System Schematic

## FUEL INJECTION

The Bendix RSA-5 fuel injection system is based on the principle of measuring engine air consumption by use of a venturi tube and using airflow to control fuel flow to the engines. Fuel distribution to the cylinders is accomplished by a fuel flow divider.

Fuel pressure regulation by means of the servo valve causes a minimal drop in fuel pressure throughout the metering system. Metering pressure is maintained above vapor forming conditions while fuel inlet pressure is low enough to allow the use of a diaphragm pump. Vapor lock and associated problems of difficult starting are thus eliminated.

Incorporated in the servo regulator is the airflow sensing system which contains a throttle valve and venturi. The differential pressure between the entrance and the throat of the venturi is the measurement of air entering the engine. These pressures are applied across an air diaphragm in the regulator. A change in power changes the airflow to the engine and across the diaphragm in the regulator.

Mounted on top of the engine is the ported fuel flow divider with six nozzle lines routed to the cylinders. The divider contains a spring loaded positive shut-off valve. Within each cylinder are continuous flow air bleed nozzles with provisions to eliminate the adverse effects of low manifold pressure when idling. Since fuel metering is provided by the servo regulator rather than the nozzles, more uniform cylinder head temperatures result and a longer engine life is possible.

An automatic alternate induction air system is provided for each engine. Should the induction air filters become obstructed by ice or other causes, the induction air doors will open automatically to provide air to the engine.

On the control pedestal are two manual alternate air controls which may be used by the pilot to select alternate air if the automatic feature should fail. These should be placed in the FULL "ON" position prior to entering known or expected icing conditions.

In the event of a turbocharger compressor failure the engine will automatically revert to normal outside air through the alternate air door.

## FUSELAGE AND WING STRUCTURE

The Aztec fuselage is a composition of four basic units; the sheet metal tail cone, cabin section, nose section, and the steel tubular structure which extends from the tail cone to the nose wheel. The steel tube unit is intended to withstand the high loads imposed on the center section region of the airplane, and provides an extra safety factor in this area.

Finish on the tubular unit, as on all steel tube structures is zinc chromate primer with synthetic enamel.

All windows are double pane except the second window on the left side which is the emergency exit window. A storm window located in the forward lower section of the pilot's side window opens downward and in when unlatched.

The wing structure is lightweight but rugged, and consists of a massive stepped down main spar, a front and rear spar, lateral stringers, longitudinal ribs, stressed skin sheets, and a detachable wing tip section. The rectangular plan form of the wing simplifies the construction while providing excellent stability and performance characteristics.

The wings are attached to the fuselage steel tubular structure with fittings at the sides and in the center of this structure, and the main spars are bolted to each other with high strength butt fittings in the center of the fuselage, giving the effect of a continuous main spar. This arrangement combines high strength and lightweight structure.

## LANDING GEAR

All three landing gear units on the Aztec incorporate the same soft acting air-oil struts, and contain many directly interchangeable parts.

Main wheels are 600 x 6 Cleveland Aircraft Products units with disc type brakes with metallic lining and 700 x 6 tires with an eight ply rating. The nose wheel is a Cleveland 600 x 6 model fitted with a 600 x 6 tire with a four ply rating.\* All tires have tubes.

Main gear brakes are actuated by toe brake pedals on the left set of rudder pedals. Hydraulic brake cylinders located in front of the left rudder pedals are readily accessible in the cockpit for servicing. Toe brakes for the right side are available as optional equipment. A brake fluid reservoir, which is connected to the brake cylinders with flexible lines, provides a reserve of fluid for the brake system, and is mounted on the fuselage structure inside the left nose access panel.

Parking brake valves, operated by a handle located on the lower left side of the instrument panel, are installed ahead of the forward cabin bulkhead, and are also serviced through the left nose access panel.

To set the parking brake, first depress and hold the toe brake pedals and then pull out the parking brake handle. To release the parking brake, first depress and hold the toe brake pedals, and then push in on the parking brake handle.

### WARNING

No braking will occur if aircraft brakes are applied while parking brake handle is pulled and held.

The nose wheel is steerable through a 30 degree arc, through use of the rudder pedals. As the nose gear retracts, the steering linkage becomes disconnected from the gear so that the rudder pedal action with the gear retracted is not impeded by nose gear operation.

The position of the landing gear is indicated by four light bulbs located on the pedestal. When the three green lights are on, all three legs of the gear are down and locked; when the amber light is on, the gear is entirely up and enclosed by the gear doors. When no light is on, the gear is in an intermediate position. On early models, the gear indication lights dim automatically when the post light control is turned on. Gear indication lights on airplanes with serial numbers 27-7554001 and up incorporate individual mechanical dimming features.

A red light in the landing gear control knob flashes when the gear is up and either one of the throttles is pulled back. When both throttles are closed (ser. nos. 27-4426, 27-4574 thru 27-7405476) beyond approximately 12 inches of manifold pressure with the gear up, the landing gear warning horn sounds. With the gear up, the landing gear warning horn will sound when either throttle is pulled back (beyond 12 inches of manifold pressure) on airplanes with serial numbers 27-554001 and up.

To guard against inadvertent retraction of the landing gear on the ground, a mechanical latch, which must be operated before the landing gear control can be moved upward, is positioned just above the control lever. The control knob is in the shape of a wheel to differentiate it from the flap control knob, which has an air-foil shape. There is also an anti-retraction valve located on the left main gear which prevents a build-up of hydraulic pressure in the retraction system while the weight of the airplane is resting on its wheels.

A tow bar is provided with each airplane. When not in use, it is stowed in the forward baggage compartment.

When towing with power equipment, caution should be used not to turn the nose gear beyond its 30 degree arc as this may cause damage to the nose gear and steering mechanism.

## HYDRAULIC SYSTEM

The hydraulic system is used for the extension and retraction of both the landing gear and the flaps. The position of the flaps or the landing gear is controlled by the levers protruding through the face of the control pedestal. The hydraulic control unit which is also a hydraulic fluid reservoir is housed within the control pedestal. Pressure for the system is supplied by the engine driven hydraulic pump mounted on the left engine. Movement of the gear or flaps occurs when hydraulic pressure is routed into actuating cylinders directly connected to the gear or flaps. Landing gear doors are also operated by the hydraulic system.

\*On turbocharged Aztec "E" only with serial no. 27-4781 and subsequent, nose tire is 600 x 6, six ply rating and should be inflated to 32 psi.

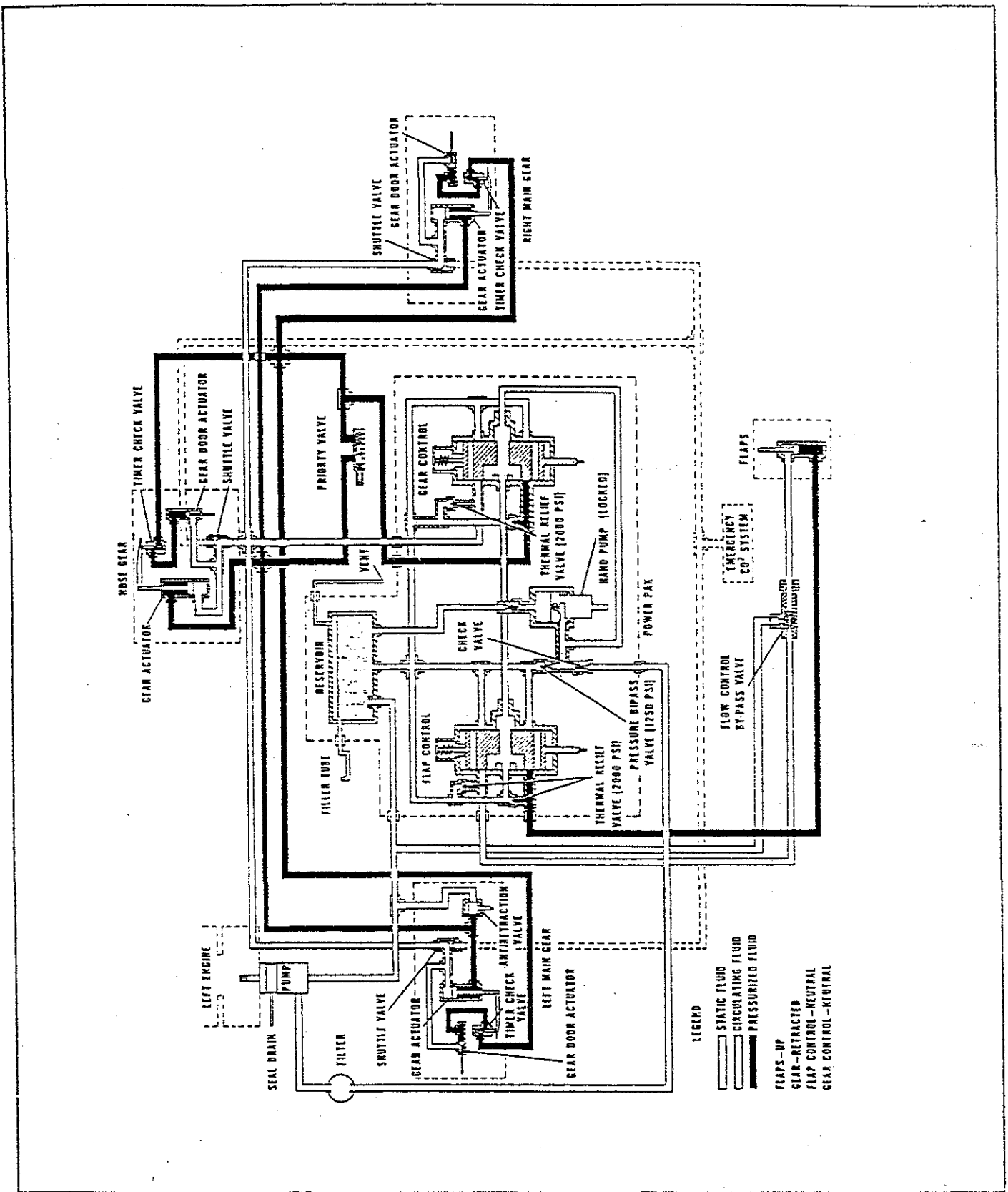

Hydraulic System Schematic

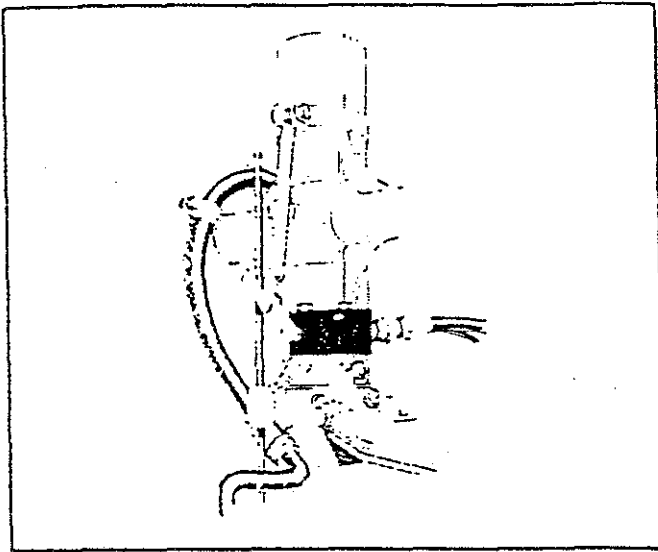

Anti-Retraction Valve

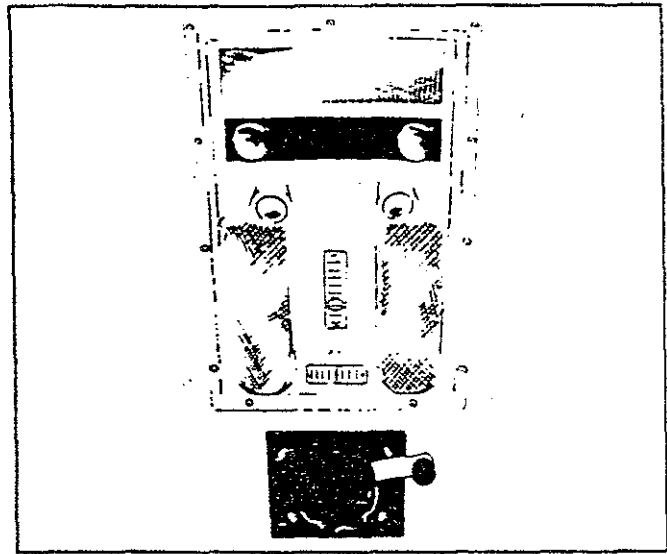

Overhead Panel

The gear control knob is wheel-shaped, and the flap control knob is airfoil-shaped. When a selector lever is in the off or neutral position, hydraulic fluid flows through selector ports and circulates freely between the engine driven pump and the control unit. For extension or retraction of gear or flaps, the respective control lever is moved from the center position into the desired direction. When a control lever is placed in an up or down position, the selector ports hydraulic fluid into the proper actuating cylinder. Once a selected component reaches full extension or retraction, hydraulic pressure within the control unit forces the control lever back into a neutral or off position, allowing hydraulic fluid to resume free circulation between the pump and the control unit. Flap travel can be stopped at any intermediate position if the control knob is manually returned to the neutral position. Although both gear and flap levers may be moved at the same time, the flaps will not extend until the gear system completes its operation; however, the flaps will "blow" up during the retraction cycle with the priority valve supplying the gear system.

When the gear or flaps have reached their selected position, the actuating cylinders and their associated lines are isolated from the hydraulic fluid supply. This feature, along with a system of check valves, insures the retention of sufficient fluid under pressure in the actuating cylinder to operate the landing gear in the event of a leak in the hydraulic system.

The emergency hydraulic hand pump, which is an integral part of the control unit, is used to obtain hydraulic pressure should the engine driven pump malfunction. The hand pump must also be used to provide hydraulic pressure when the left engine is inoperative. To operate the hand pump, the handle should be pulled aft to its full extension and the gear or flap selector positioned as desired. Approximately fifty strokes are required to raise or lower the landing gear. At altitudes above 10,000 feet, the hand pump becomes increasingly inefficient.

An additional back-up system exists independent of the need for hydraulic fluid. The system is powered by a CO<sub>2</sub> cylinder, and emergency extension of the landing gear may be accomplished by this CO<sub>2</sub> system. The control for the CO<sub>2</sub> system is located beneath a small cover plate under the pilot's seat. When the control is pulled, the gear selector must be in the down position. Pulling the emergency gear extender ring releases CO<sub>2</sub> from a cylinder under the floor panel. The gas flows into the gear actuating cylinders, extending the landing gear. Note that this system may be used for gear extension only; it must never be used for gear retraction or operation of the flaps.

The landing gear position lights and the flap indicator, along with visual observation, should be used as primary indications of the positions of gear and flaps. The mirror on the right side of the left nacelle shows the position of the nose gear. Secondary indication that gear and flaps have reached their selected position is the return of the control lever to the off or neutral position.



The left main gear includes a by-pass valve which prevents the retraction of the landing gear while the airplane is on the ground. The weight of the airplane causes the valve to remain open while the strut is compressed, and all fluid by-passes directly from the pressure side of the system to the return side, preventing any build-up of hydraulic pressure in the retraction system. Note that this system is designed to prevent inadvertent retraction during aircraft start-up. The by-pass valve cannot be relied upon as the sole means of preventing retraction during high engine power on the ground or during taxi and takeoff operations. Be sure the gear handle is down before moving the aircraft.

## CONTROL SYSTEM AND SURFACES

Dual flight controls are provided in the Aztec as standard equipment. All controls are light, yet solid and effective in flight at all speeds down through the stalling speed. The nose wheel is steerable on the ground through the rudder pedals.

All control surfaces are cable controlled and are conventional sheet metal structures fitted with aluminum hinges and needle bearings. The flaps are actuated by a hydraulic cylinder located in the right side of the cabin wall. Access to this cylinder is obtained by the removal of the upholstered interior panel directly aft of the entrance door, under the side windows.

The ailerons and rudder are connected by cables with the control wheel and rudder pedals. The rudder has a servo tab which also acts as a directional trim tab, actuated by a knob in the center of the forward cabin ceiling.

The horizontal tail is a stabilator, with an anti-servo tab which also acts as longitudinal trim tab, actuated by a larger crank concentric with the rudder tab knob in the center of the forward cabin ceiling. The stabilator provides extra stability and controllability with less size, drag and weight than with conventional horizontal tail surfaces.

## FUEL SYSTEM

Four thirty-six gallon flexible fuel cells located outboard of the engines provide fuel storage in the Aztec. The cells should be kept full of fuel during storage of the airplane to prevent accumulation of moisture, and to prevent deterioration of the cells. For storage of more than ten days without fuel, the cells should be coated with light engine oil to keep from drying out.

The fuel system in the Aztec is simple, but completely effective. Fuel can be pumped from any tank to either engine, through use of the engine-driven and electric fuel pumps.

For normal operation, fuel is pumped by the engine-driven pumps from the tanks directly to the adjacent fuel injector. The fuel valves can be left on at all times and the crossfeed left in the off position. Electric auxiliary fuel pumps, located in the engine nacelles, are installed in by-pass fuel lines between the tanks and the engine-driven pumps. The electric pumps can be used to provide pressure in the event of failure of the engine-driven pumps. They are normally turned on to check their operation before starting the engines, turned off after starting, to check engine-driven pumps and left on during take-off and landing, to preclude the possibility of fuel pressure loss due to pump failure at critical times. If one of the engine-driven pumps fails, the electric pump to that engine can be turned on to supply the fuel.

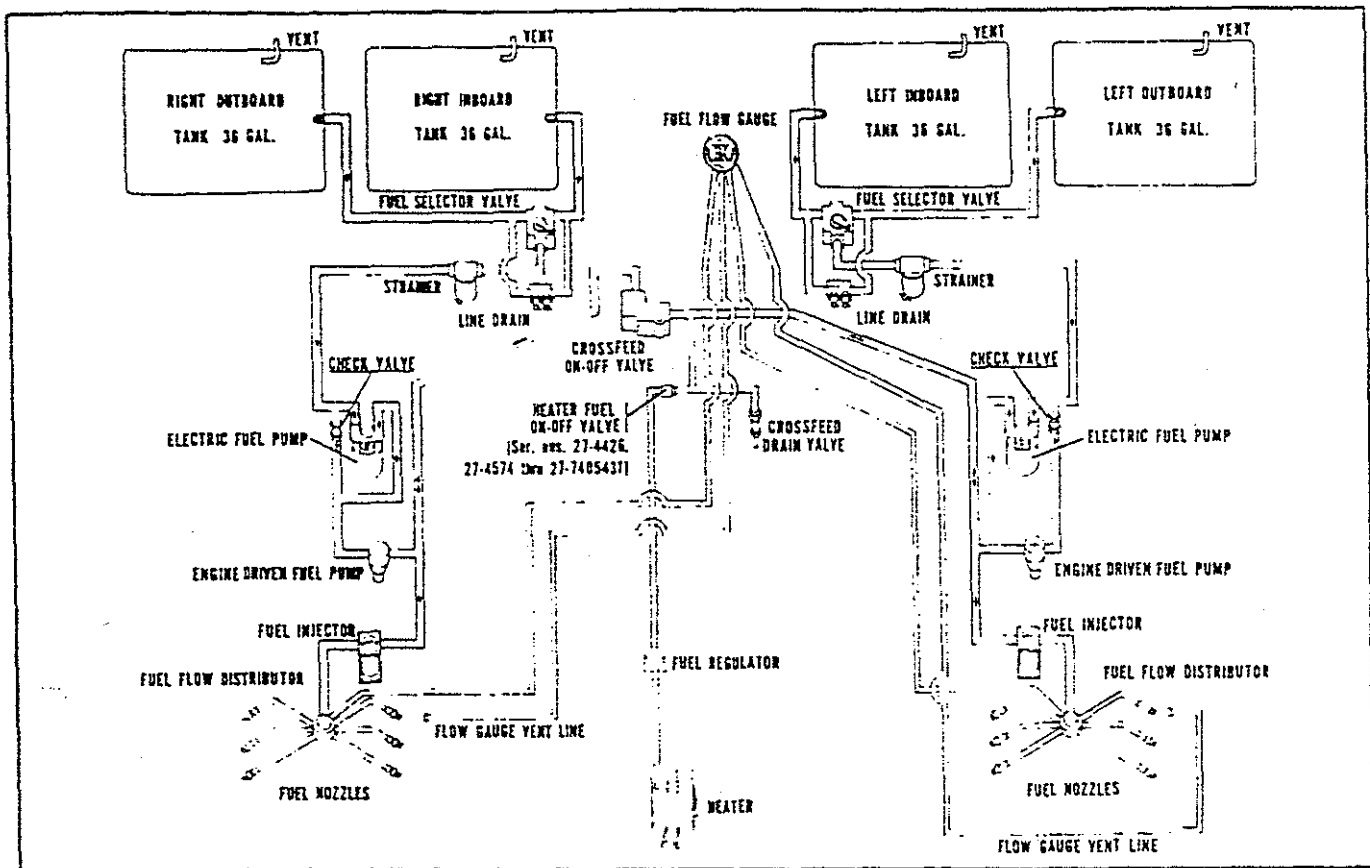

Fuel System Schematic

A pressure crossfeed system is incorporated for extended range during single-engine operation. To utilize the fuel on the inoperative engine side, turn the crossfeed on, the main fuel valve of the inoperative engine on, the electric fuel pump of the inoperative engine on, then the main fuel valve of the operating engine off.

Fuel can thus be used from one tank or the other, by shutting off one main valve and turning on the crossfeed, to balance fuel loads or to extend range. For all normal operation, it is recommended that fuel be pumped directly from the tanks to their respective engines, with the crossfeed off.

The fuel valve controls and crossfeed control are located in the fuel control panel between the front seats. Two electric fuel gauges in the engine gauge cluster on the instrument panel indicate the fuel quantity in each tank. The electric fuel gauges indicate the fuel quantity in the tank selected by the fuel selector handle, located in the fuel control box. The electric fuel pump switches are on the lower left side sub-panel.

A crossfeed line drain valve control is mounted on the front face of the fuel control panel box. This valve should be opened occasionally, with the crossfeed on, the left electric fuel pump on, and then the right electric fuel pump on to allow any water that might accumulate at that point to be drained out. On airplane serial numbers 27-4426, 27-4574 through 27-7405431, a heater fuel control is also placed on the fuel control panel so that fuel to the heater can be turned off if necessary.

The fuel strainers and fuel line drain valves are located in the inboard sides of the main wheel wells. They are fitted with quick drains and should be drained regularly through their small access ports. In order to check the fuel system for possible moisture content, each fuel cell quick drain valve should be opened and drained and the quick drain valve on the fuel strainer should be opened and drained. This procedure should be accomplished at the three quick drain valves located in each main wheel well. Fuel screens are provided at the tank outlets, in the injectors and in the fuel filter bowls.

Idle cut-offs are incorporated in the injectors and should always be used to stop the engines. This is accomplished by pulling the mixture control levers to the rearmost position.

Electrical Schematic  
(Up to and including Serial No. 27-4793)

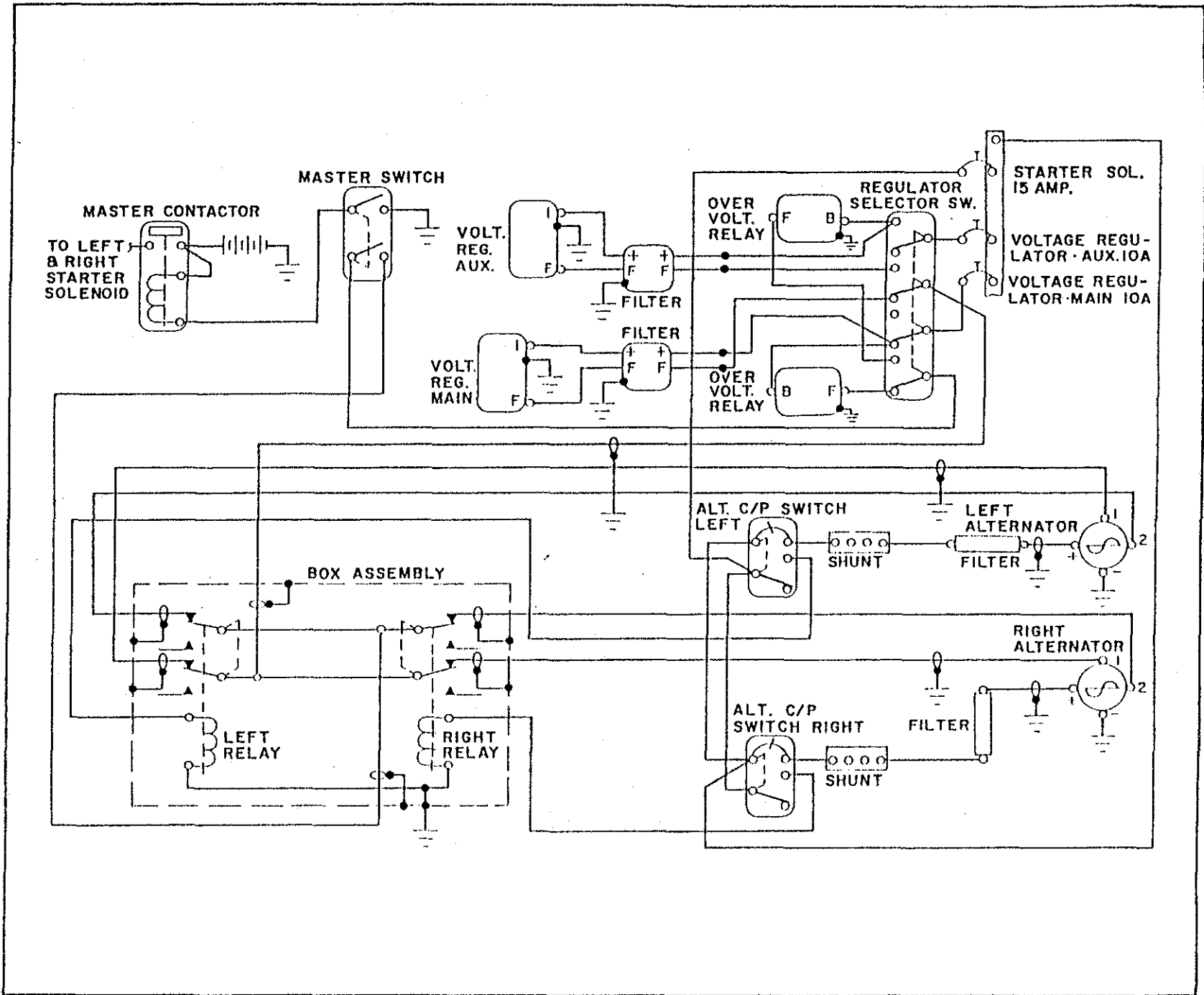

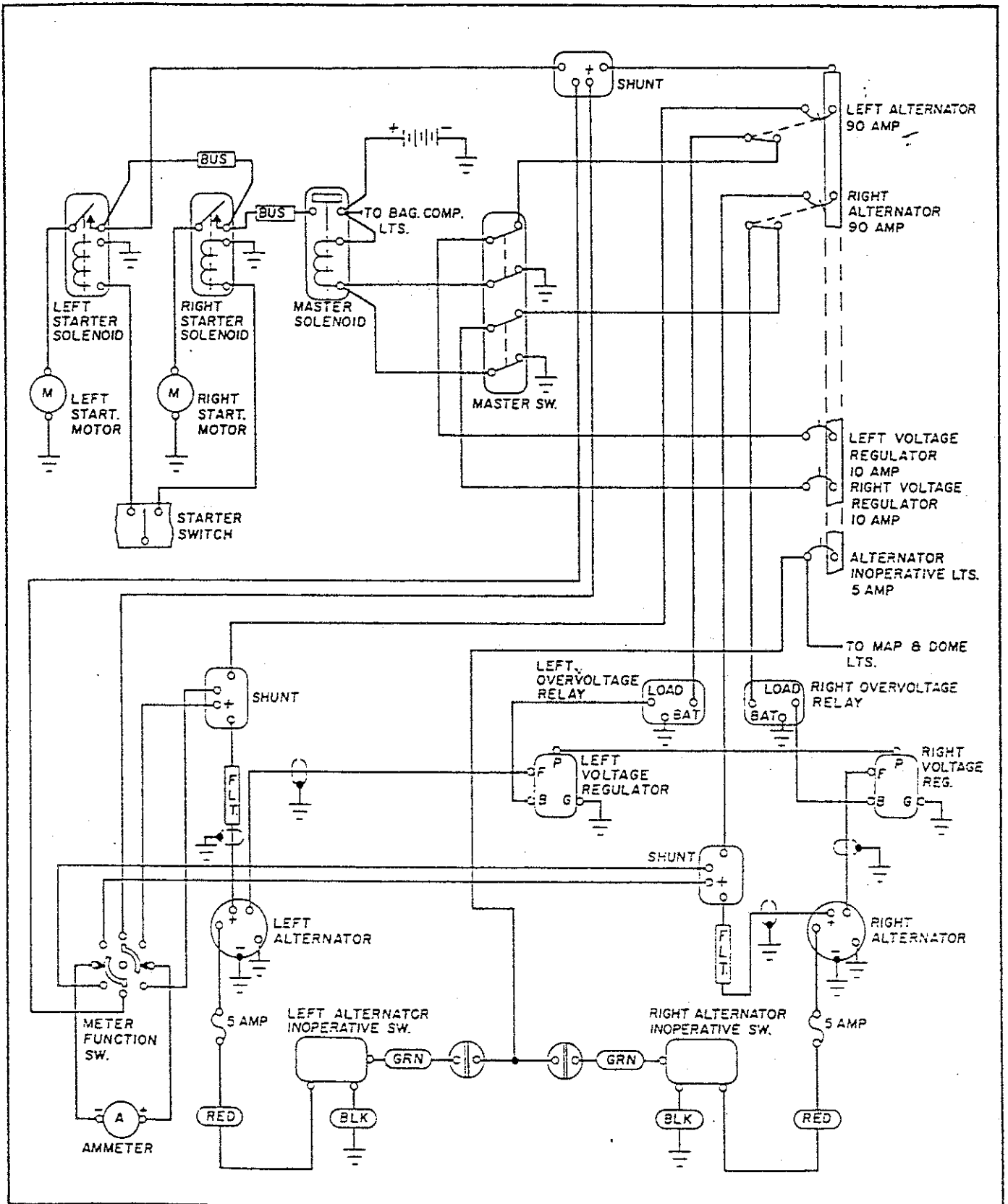

Electrical Schematic  
(Aircraft Serial No. 27-4794 and up)

## ELECTRICAL SYSTEM

The electrical system for the Aztec includes a 12 volt 35 ampere hour battery or a 24 volt 17 ampere hour battery, enclosed in a sealed stainless steel battery box. Installed are two 12 volt 70 ampere alternators or two 24 volt 70 ampere alternators respectively.

There are two voltage regulator systems installed in the Aztec aircraft.

On aircraft up to and including serial number 27-4793 the alternators are coupled by using one voltage regulator to control field voltage of both alternators. Also incorporated in the system is an overvoltage relay. Its function is to open and remove field voltage to the unregulated alternators in the event of a failure of the voltage regulator, thus preventing an overvoltage which could damage the electrical equipment.

As an added feature, to provide for complete dual system reliability, an auxiliary voltage regulator and overvoltage relay has been installed. Each set of regulators and relays is controlled by a switch located on the left sub-panel next to the master switch. The switch is placarded "Voltage Regulator Selector," "Main," and "Auxiliary." The switch should normally be in the "Main" position. The operation of the alterators may be checked by an ammeter switch located directly under the ammeter.

## NOTE

Refer to the Airplane Flight Manual Section for corrective action for a voltage regulator failure.

## NOTE

If the battery is completely discharged, remove the battery and charge prior to starting engines.

On aircraft with serial number 27-4794 and up, the electrical system incorporates an alternator paralleling system. The system has two voltage regulators which control the alternators. The regulators are interconnected electrically to provide parallel outputs from their respective alternators under normal operating engine RPM's. Whenever the engines are operating at a high differential RPM, the alternator inoperative light for the slower engine may come on.

Alternator inoperative lights are located below the ammeter. The lights illuminate when the respective alternator fails to provide voltage. The lights should be checked prior to starting the engines, to see if the bulbs are burned out, by turning on the master switch. If the bulbs do not illuminate the bulbs should be replaced.

A distinctive feature of the alternators paralleling system is the split rocker type master switch and the alternator inoperative lights.

## NOTE

Refer to the Airplane Flight Manual Section for corrective action for an alternator failure.

Electrical switches for the various systems are located on both sub-panels of the instrument panel. The circuit breakers are on the right side sub-panel. To reset the circuit breakers simply push in the reset button. Reduce the electrical load to minimum and allow two minutes before resetting the breakers. Corrective action should be taken in event of continual circuit breaker popping. The alternator circuit breakers, mounted on the same panel, are of the switch type and should not be turned off while the engines are running.

Instrument lighting is provided by two spotlights installed in the center of the cabin ceiling. (S/N up to and including 27-4803.) These lights are operated by a rheostat switch which is located directly aft of the lights. The lights are turned on with the first movement of the rheostat knob and the light intensity increased by further rotation of the control. Provided as optional equipment (standard on S/N 27-4804 and up) are individual post lamps mounted on the panel adjacent to each instrument. These lights are controlled by a rheostat switch located on the panel with the other electrical switches. Operation of the rheostat is the same as for the spotlights. Located in the cabin ceiling just aft of the windshield, on both the right and left sides, are map lights equipped with clear lenses. Each light is operated by the switch located adjacent to the unit. For the passengers, reading lights are installed over each seat as well as a cabin dome light located in the center of the cabin ceiling. A separate switch is used for each of these units.

There are overhead lights in both the forward and aft baggage compartments. They will turn on and off with the opening and closing of the baggage doors. On the upper right side of the instrument panel is a red warning light labeled "Door Ajar". It will light if the master switch is on and either the forward baggage door or main cabin door is not completely closed and latched.

### CAUTION

Do not leave either baggage compartment door open for extended periods.

The starter and magneto switches are on the left side panel near the instrument panel. The starter switch is of the momentary rocker type.

An external power receptacle, located in the lower right side of the nose, is available as optional equipment. Turn the master switch off before inserting or removing a plug at this receptacle. Leave the master switch off while using external power.

### INSTRUMENT PANEL

The instrument panel of the Aztec is designed to accommodate all of the customary advanced flight instruments and all required engine instruments. Space is provided for the installation of optional navigational and radio equipment, as well as optional copilot's instruments. The instrument panel is shock mounted and lighted, and all instruments are accessible for maintenance.

The flight instrument group includes the airspeed indicator, the rate of climb indicator, and the altimeter, which are operated by the pitot-static system; the directional gyro and the artificial horizon, which are operated by the vacuum system; and an electrically operated turn coordinator, which serves as a standby in the event of a gyro instrument failure. Gyro instruments employ vacuum pumps installed on each engine. The gyro suction gauge on the instrument panel should indicate 4.8 to 5.1 inches of mercury for proper operation of the gyro instruments.

Engine instruments include recording tachometers, a dual manifold pressure gauge, and a dual fuel flow gauge. A cluster of fuel and engine gauges incorporates fuel quantity, oil pressure, oil temperature, and cylinder head temperature indicators for each engine. On earlier models there is a separate tachometer for each engine; on later models there is a dual tachometer. A dual exhaust gas temperature gauge is provided on turbocharged models.

Radio equipment is mounted in the center and autopilot controls are mounted on the lower left of the instrument panel. Electrical switches and the circuit breaker panel are installed along the bottom of the instrument panel. The ammeter, located on the right side of the instrument panel, can be set to show the condition of the battery or the output of either alternator.

The instrument panel also includes various warning lights, the cabin heat control, an engine hour meter and microphone and earphone jacks.

Instrument Panel for Ser. Nos. 27-4426 through 27-7305221, 27-7305223 through 27-7305234

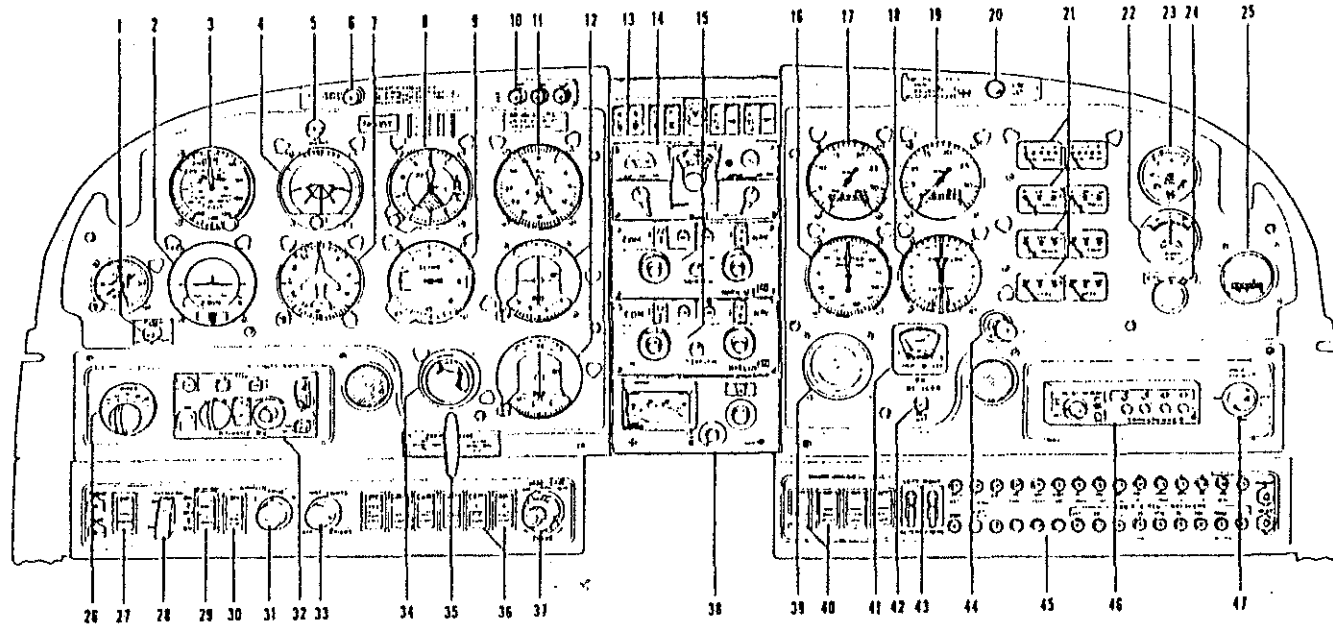

- |                             |                               |                                |
|-----------------------------|-------------------------------|--------------------------------|
| 1. TRIM INDICATOR LIGHT     | 17. TACHOMETER, LEFT          | 33. PANEL LIGHTS               |
| 2. TURN COORDINATOR         | 18. FUEL FLOW GAUGE           | 34. FLAP POSITION INDICATOR    |
| 3. AIRSPEED INDICATOR       | 19. TACHOMETER, RIGHT         | 35. PARKING BRAKE              |
| 4. GYRO HORIZON             | 20. DOOR AJAR LIGHT           | 36. FUEL PUMP SWITCHES         |
| 5. G/S COUPLER LIGHT        | 21. FUEL/ENGINE GAUGE CLUSTER | 37. PROP SYNCHRONIZER CONTROL  |
| 6. STALL WARNING LIGHT      | 22. AMMETER                   | 38. DME CONTROL                |
| 7. DIRECTIONAL GYRO         | 23. GYRO SUCTION GAUGE        | 39. PANEL                      |
| 8. ALTIMETER                | 24. ALTERNATOR SWITCH         | 40. DEICER SWITCHES            |
| 9. RATE OF CLIMB            | 25. HOUR METER (TOTAL)        | 41. AMMETER - PROP DEICER      |
| 10. MARKER BEACON           | 26. NAV/APPROACH COUPLER      | 42. PNEUMATIC DEICER INDICATOR |
| 11. ADF INDICATOR           | 27. MASTER SWITCH             | 43. ALTERNATOR SWITCHES        |
| 12. OMNI BEARING SELECTOR   | 28. VOLTAGE REGULATOR         | 44. LIGHTER                    |
| 13. JUNCTION BOX            | 29. TRANSMITTER SELECTOR      | 45. CIRCUIT BREAKERS           |
| 14. ADF RADIO               | 30. AUTOFLITE SWITCH          | 46. TRANSPONDER                |
| 15. COMM/NAV TRANSCEIVERS   | 31. AUTOFLITE TRIM            | 47. HEAT CONTROL               |
| 16. MANIFOLD PRESSURE GAUGE | 32. ALTIMATIC IIIB            |                                |

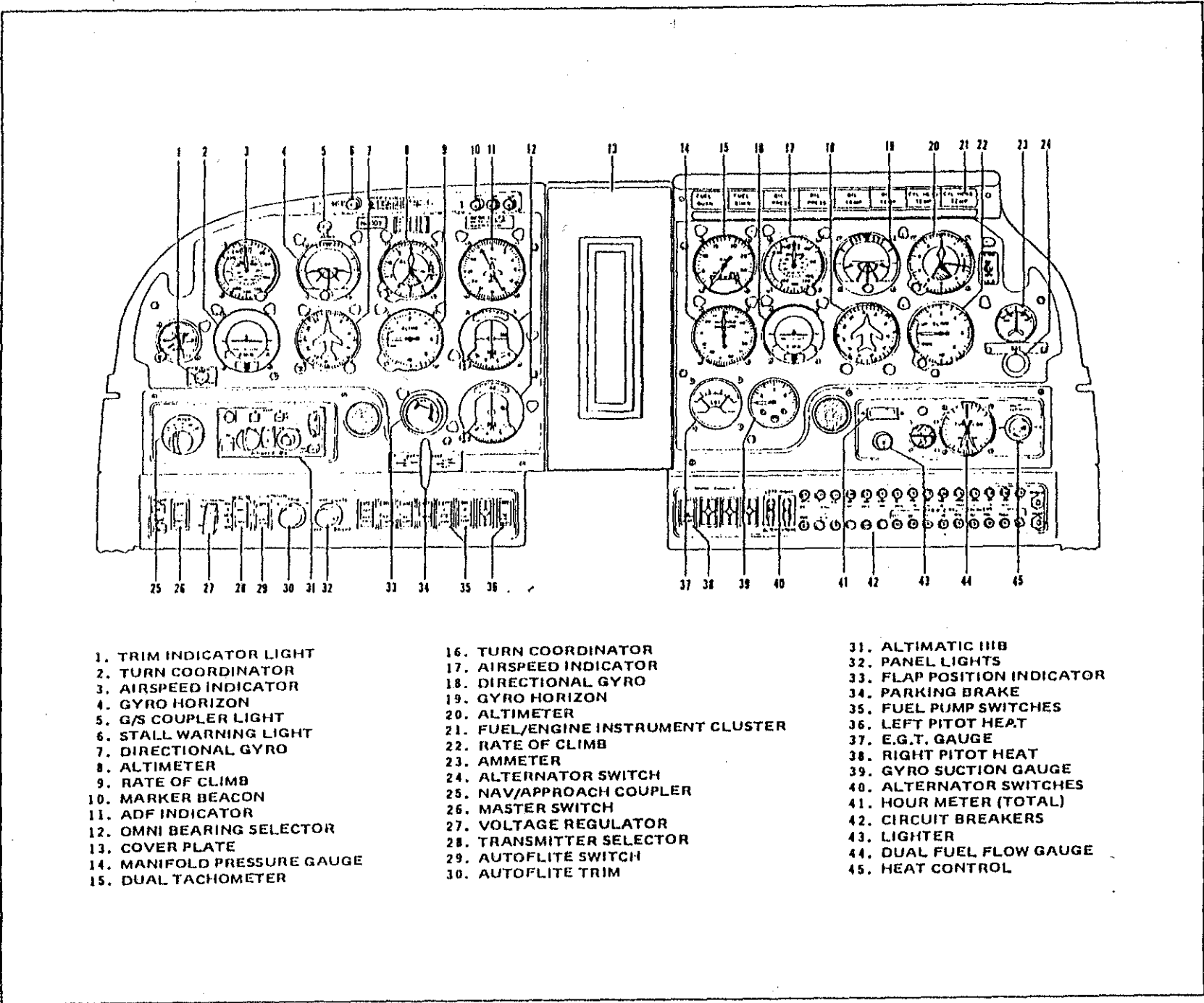

Instrument Panel for Ser. Nos. 27-7305222, 27-7405235 through 27-7405476

- |                             |                                    |                             |
|-----------------------------|------------------------------------|-----------------------------|
| 1. TRIM INDICATOR LIGHT     | 16. TURN COORDINATOR               | 31. ALTIMATIC III B         |
| 2. TURN COORDINATOR         | 17. AIRSPEED INDICATOR             | 32. PANEL LIGHTS            |
| 3. AIRSPEED INDICATOR       | 18. DIRECTIONAL GYRO               | 33. FLAP POSITION INDICATOR |
| 4. GYRO HORIZON             | 19. GYRO HORIZON                   | 34. PARKING BRAKE           |
| 5. G/S COUPLER LIGHT        | 20. ALTIMETER                      | 35. FUEL PUMP SWITCHES      |
| 6. STALL WARNING LIGHT      | 21. FUEL/ENGINE INSTRUMENT CLUSTER | 36. LEFT PITOT HEAT         |
| 7. DIRECTIONAL GYRO         | 22. RATE OF CLIMB                  | 37. E.G.T. GAUGE            |
| 8. ALTIMETER                | 23. AMMETER                        | 38. RIGHT PITOT HEAT        |
| 9. RATE OF CLIMB            | 24. ALTERNATOR SWITCH              | 39. GYRO SUCTION GAUGE      |
| 10. MARKER BEACON           | 25. NAV/APPROACH COUPLER           | 40. ALTERNATOR SWITCHES     |
| 11. ADF INDICATOR           | 26. MASTER SWITCH                  | 41. HOUR METER (TOTAL)      |
| 12. OMNI BEARING SELECTOR   | 27. VOLTAGE REGULATOR              | 42. CIRCUIT BREAKERS        |
| 13. COVER PLATE             | 28. TRANSMITTER SELECTOR           | 43. LIGHTER                 |
| 14. MANIFOLD PRESSURE GAUGE | 29. AUTOFLITE SWITCH               | 44. DUAL FUEL FLOW GAUGE    |
| 15. DUAL TACHOMETER         | 30. AUTOFLITE TRIM                 | 45. HEAT CONTROL            |



Instrument Panel for Ser. Nos. 27-7554001 and up

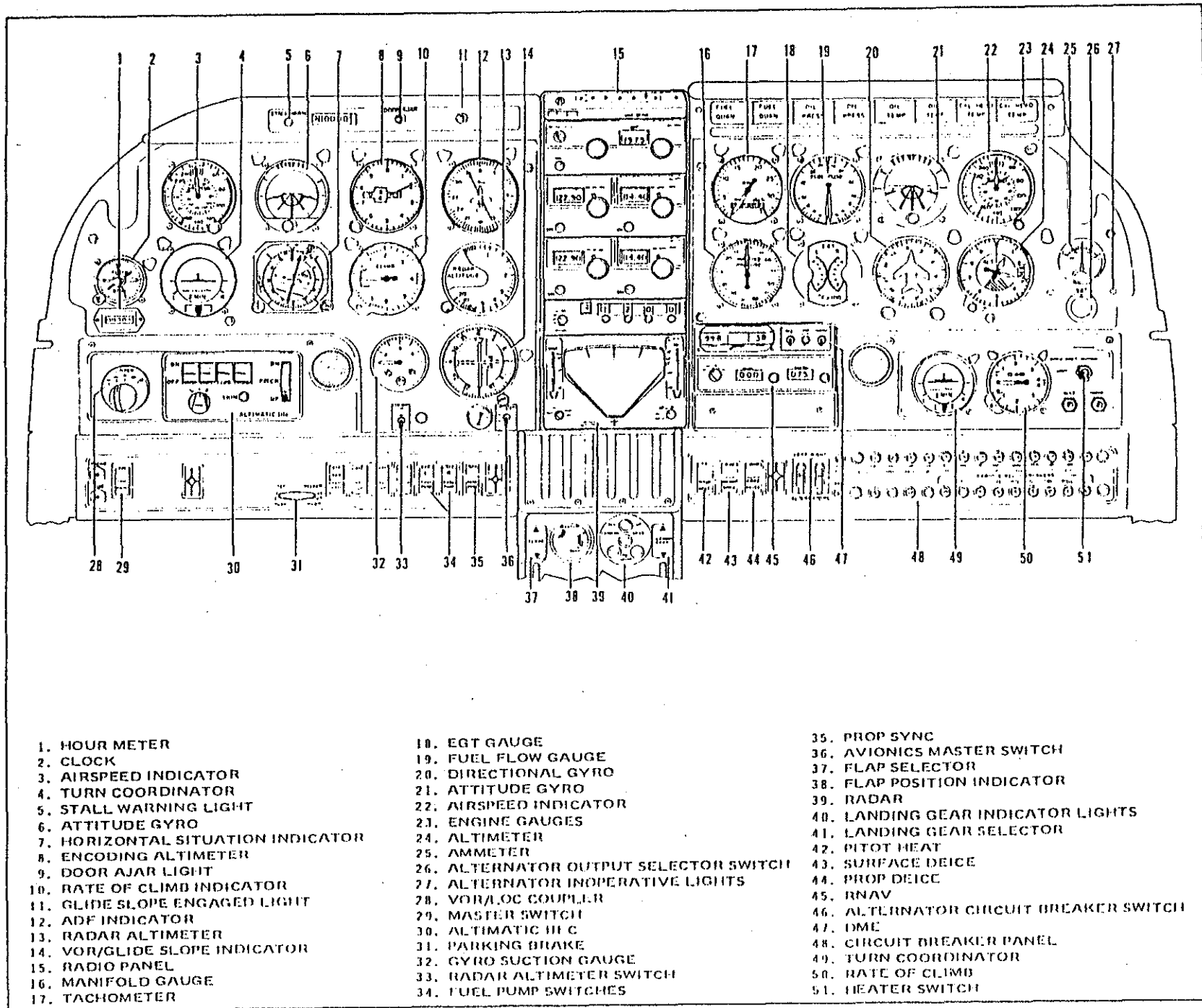

- |                                   |                                       |                                       |
|-----------------------------------|---------------------------------------|---------------------------------------|
| 1. HOUR METER                     | 10. EGT GAUGE                         | 35. PROP SYNC                         |
| 2. CLOCK                          | 19. FUEL FLOW GAUGE                   | 36. AVIONICS MASTER SWITCH            |
| 3. AIRSPEED INDICATOR             | 20. DIRECTIONAL GYRO                  | 37. FLAP SELECTOR                     |
| 4. TURN COORDINATOR               | 21. ATTITUDE GYRO                     | 38. FLAP POSITION INDICATOR           |
| 5. STALL WARNING LIGHT            | 22. AIRSPEED INDICATOR                | 39. RADAR                             |
| 6. ATTITUDE GYRO                  | 23. ENGINE GAUGES                     | 40. LANDING GEAR INDICATOR LIGHTS     |
| 7. HORIZONTAL SITUATION INDICATOR | 24. ALTIMETER                         | 41. LANDING GEAR SELECTOR             |
| 8. ENCODING ALTIMETER             | 25. AMMETER                           | 42. PITOT HEAT                        |
| 9. DOOR AJAR LIGHT                | 26. ALTERNATOR OUTPUT SELECTOR SWITCH | 43. SURFACE DEICE                     |
| 10. RATE OF CLIMB INDICATOR       | 27. ALTERNATOR INOPERATIVE LIGHTS     | 44. PROP DEICC                        |
| 11. GLIDE SLOPE ENGAGED LIGHT     | 28. VOR/LOC COUPLER                   | 45. RNAV                              |
| 12. ADF INDICATOR                 | 29. MASTER SWITCH                     | 46. ALTERNATOR CIRCUIT BREAKER SWITCH |
| 13. RADAR ALTIMETER               | 30. ALTIMATIC III C                   | 47. DME                               |
| 14. VOR/GLIDE SLOPE INDICATOR     | 31. PARKING BRAKE                     | 48. CIRCUIT BREAKER PANEL             |
| 15. RADIO PANEL                   | 32. GYRO SUCTION GAUGE                | 49. TURN COORDINATOR                  |
| 16. MANIFOLD GAUGE                | 33. RADAR ALTIMETER SWITCH            | 50. RATE OF CLIMB                     |
| 17. TACHOMETER                    | 34. FUEL PUMP SWITCHES                | 51. HEATER SWITCH                     |

THIS PAGE INTENTIONALLY LEFT BLANK

## HEATING AND VENTILATING SYSTEM

The flow of air for cooling or heating the Aztec cabin is controlled by the five knobs on the cabin air control panel located at the bottom of the control pedestal.

The left control regulates air flowing to the front seat through the heater system and the second knob from the left controls air flowing to the rear seat through this system. The middle knob controls the heater thermostat. The second knob from the right is the defroster control and the right hand control supplies additional cold air to the front seat through a vent on the bulkhead.

Cabin air enters the heater system through an inlet above the landing light, and when the heater is not in operation, the inlet can serve as a source for cool air by pulling out the heater controls.

A 35,000 B.T.U. Janitrol heater installed in the nose section furnishes a source of hot air for cabin heating and windshield defrosting.

Operation of the heater is controlled by a three position switch located on the right side of the instrument panel, labeled "FAN", "OFF" and "HEAT". The "FAN" position will operate the vent blower only and may be used for cabin ventilation on the ground or windshield defogging when heat is not desired.

For heat, the three position heater switch must be turned to "HEAT". On airplane serial numbers 27-4426, 27-4574 through 27-7405431, the manual heater fuel valve must also be on. This will start fuel flow and ignite the burner simultaneously. With instant starting and no need for priming, heat should be felt within a few seconds.

Regulation of heat, airflow and defroster operation is controlled by the push-pull knobs on the cabin air control panel. The middle knob is connected to an adjustable thermostat which makes it possible to select a desired temperature of heated air through a wide range.

Cabin temperature and air circulation can be maintained by using various combinations of knob settings, to suit individual desires. To minimize the feeling of drafts, a low air flow-high heat combination should be used.

Windshield defrosting may be regulated by various settings of the defroster knob and in severe windshield fogging or icing conditions, it may be desirable to restrict the heater air, since this will drive more air through the defrosters.

When heat is no longer desired, the three position switch may be turned to the "OFF" position and the manual fuel valve, if installed, closed. When the heater has been operating with the airplane on the ground, turn the switch to "FAN" for several minutes to cool the heater. It may then be turned off.

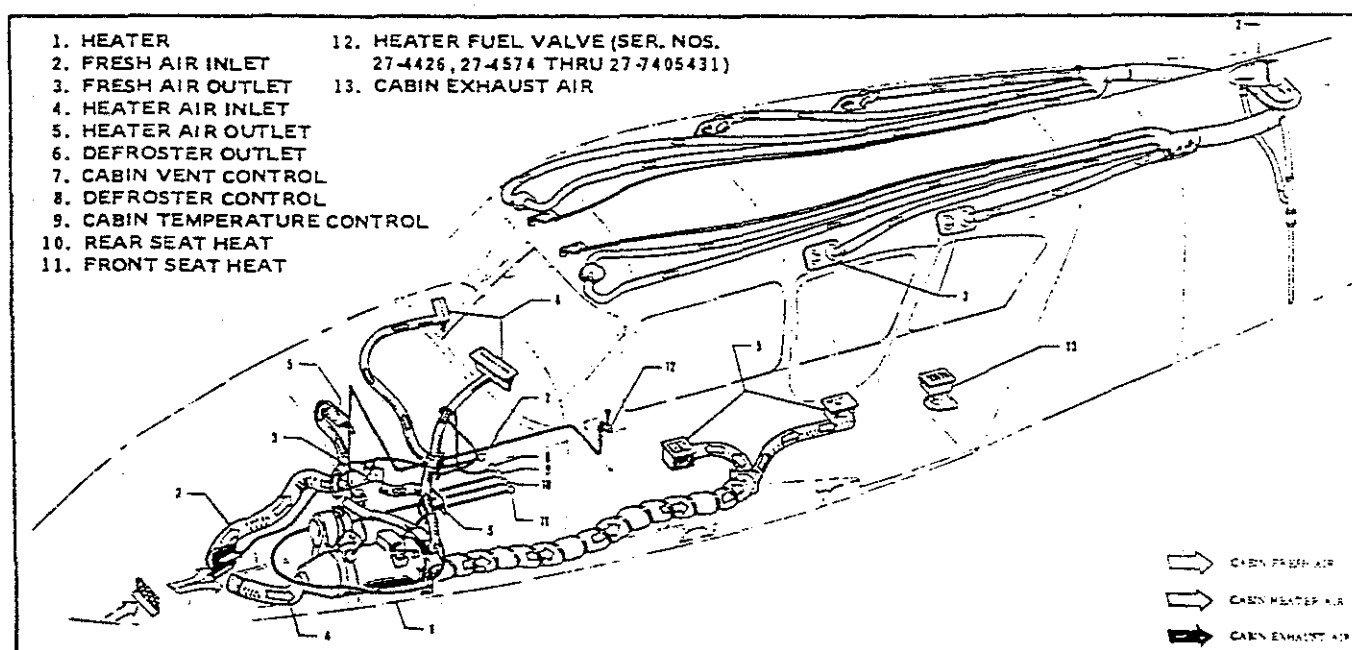

Heating and Ventilating System

AIRPLANE AND SYSTEMS

REVISED: May 31, 1974

PAGE 11

Heat may be supplied to warm the cabin before flight by turning on the master switch, the left auxiliary fuel pump, and starting the heater. It should not be used in such a way as to deplete the battery.

The cabin heater uses gasoline from the left main fuel tank when the crossfeed is off and from both tanks when the crossfeed is on.

Located in the heater is an overheat lockout switch which acts as a safety device to render the heater system inoperative if a malfunction should occur causing excessively high temperatures. This control is located in the downstream end of the vent jacket, with the reset button on the heater shroud. It is reached only through the access panel in the left side of the nose section to insure that the malfunction causing the overheat condition is corrected prior to further heater operation.

For fresh air ventilation, an air scoop is mounted on the dorsal fin which draws air into the cabin through overhead vents in the ceiling. Each individual vent is adjustable for desired air flow. Two master control knobs are located in the ceiling just aft of the windshield. These control the air supply to the right and left overhead vents. Air is exhausted through an outlet on the floor of the aft baggage compartment.

### FINISH

All sheet aluminum components of the Aztec are carefully finished inside and outside to assure maximum service life. Both sides of all pieces are alodine treated, and sprayed with zinc chromate primer. External surfaces are coated with durable acrylic lacquer in attractive high gloss colors. The application of primer to interior surfaces prevents corrosion of structural and non-structural parts where inaccessible for normal maintenance.

### BAGGAGE COMPARTMENTS

There are two large baggage compartments, each compartment is placarded for 150 pounds. The forward compartment provides 21.3 cubic feet of space accessible through a door measuring an average of 19.5 x 30.5 inches. The rear compartment has a volume of 26.2 cubic feet with door measuring about 30 x 31 inches and hinged on the forward side.

### SEATS

All seats in the Aztec are constructed of steel tubing, foam cushions on rubber bladders and headrests. The crew seats will slide fore and aft through a seven inch range by operation of the release control on the front of each seat. The right side crew seat adjusts aft beyond the normal range to provide ease of entry to the pilot's seat. To remove either of the front seats, remove the stop plates from the tracks at the rear of the seat structure, and slide the seat forward and off the tracks.

The passenger area is equipped with two individual bucket seats and a couch seat that accommodates two people. To remove the center seats, remove the stop plates from the tracks and slide the seats forward then aft as required to disengage the seat supports from their tracks. The rear seat can be removed for added cabin space by pulling the back of the seat forward, then lifting it out. Pull the bottom of the seat forward to disengage the pins at the rear, then push it rearward to disengage the seat supports from the floorboards.

All six seats are provided with headrests.

### CABIN FEATURES

Removable armrests for front and middle seats, coat hangers, ash trays, a cigarette lighter, reading lights and pilot's map pocket are all standard. The cabin door and baggage doors are equipped with locks. The locks on both baggage doors are operated by one key, while the cabin door has a separate key.

---

## RADIO EQUIPMENT

In the standard model of the Aztec, provisions for radio installations include dual microphone and headset jacks, a microphone, overhead loud speakers and panel space for four radio sets. Radios are available in different combinations to provide in the Aztec all of the most recent radio developments normally desired in this type of aircraft.

Located to the rear of the forward baggage compartment is a shelf providing ample room for power supplies for the various radios installed.

AIRPLANE FLIGHT MANUAL  
F. A. A. APPROVED

AIRPLANE FLIGHT MANUAL  
F. A. A. APPROVED

FAA APPROVED

# AIRPLANE FLIGHT MANUAL

FOR

## AZTEC "E"

Serial Number 27-4426, 27-4574 and up

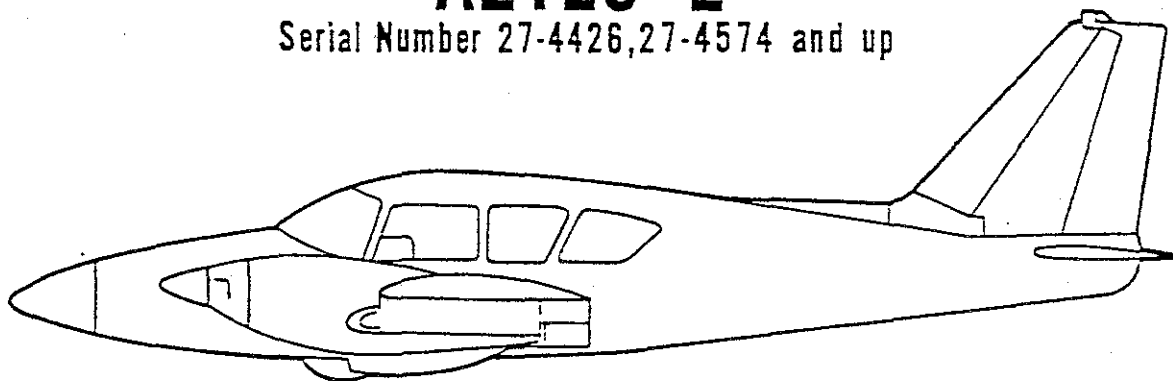

### NOTE

THIS MANUAL MUST BE KEPT IN THE AIRPLANE AT ALL TIMES

MANUFACTURER'S MODEL - PA-23-250(Six Place)

MANUFACTURER'S SERIAL - 27-4786

REGISTRATION - N 14228

FAA APPROVED BY:

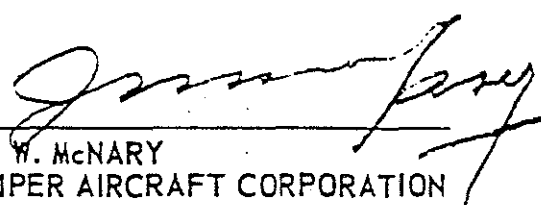
  
J. W. McNARY  
PIPER AIRCRAFT CORPORATION  
D. O. A. No. EA-1  
LOCK HAVEN, PENNSYLVANIA

DATE OF APPROVAL: JANUARY 21, 1970

APPROVAL BASIS: CAR 3 AND FAR PART 21, SUBPART J.  
NORMAL CATEGORY

## TABLE OF CONTENTS

SECTION I		Page
Log of Revisions	.....	1
SECTION II		
Limitations	.....	3
A. Engine	.....	3
B. Fuel	.....	3
C. Propellers	.....	3
D. Cowl Flaps	.....	3
E. Wing Flaps	.....	3
F. Instrument Markings (Power Plant)	.....	3
G. Airspeed Limitations and Indicator Markings (Calibrated Airspeed)	.....	4
H. Flight Load Factors	.....	4
I. Maximum Weight	.....	4
J. C.G. Range	.....	4
K. Maneuvers	.....	5
L. Placards	.....	5
SECTION III		
Procedures	.....	7
A. Systems Operation and Checks	.....	7
1. Voltage Regulating and Alternator System (For Aircraft up to and including Serial No. 27-4793)	.....	7
2. Alternator Paralleling System (For Aircraft Serial No. 27-4794 and up)	.....	8
3. Fuel Management	.....	8
4. Landing Gear and Flap Extension - Emergency	.....	9
5. Stall Warning Indicator	.....	9
B. Emergency Procedures	.....	11
1. Feathering Procedure	.....	11
2. Unfeathering Procedure	.....	11
3. Emergency Exit	.....	11
SECTION IV		
Performance	.....	13
SECTION V		
Supplements	.....	15
1. Icing Equipment Installation	.....	17
2. Oxygen System Installation	.....	19
1. Limitations	.....	19
2. Procedures	.....	19
3. Placards	.....	19
4. Emergency	.....	19

FAA APPROVED January 21, 1970  
 REVISED: October 1, 1974

REPORT: 1630 PART I PAGE i  
 MODEL: PA-23-250 (Six Place)  
 SN 27-4426, 27-4574 and up



3.	Installation of Piper AutoControl III . . . . .	21
1.	Limitations . . . . .	21
2.	Operating Instructions . . . . .	21
3.	Normal Operation . . . . .	21
4.	Emergency Procedures . . . . .	21
4.	Installation of Lycoming Turbocharged Engines . . . . .	23
1.	Limitations . . . . .	23
2.	Normal Operating Procedures . . . . .	24
3.	Performance . . . . .	24
5.	Installation of Piper AltiMatic IIIB . . . . .	25
1.	Limitations . . . . .	25
2.	Operating Instructions . . . . .	25
3.	Normal Flight Operation . . . . .	26
4.	Emergency Procedures . . . . .	27
5.	Placards . . . . .	27
6.	Installation of Anti-Collision (Strobe) Lights . . . . .	29
1.	Operating Limitations . . . . .	29
7.	Installation of AltiMatic V F/D . . . . .	31
1.	Limitations . . . . .	31
2.	Normal Operating Procedures . . . . .	31
3.	Emergency Operating Procedure . . . . .	34
4.	Placards . . . . .	35
8.	Installation of AltiMatic V . . . . .	37
1.	Limitations . . . . .	37
2.	Normal Operating Procedures . . . . .	37
3.	Emergency Operating Procedure . . . . .	40
4.	Placards . . . . .	40
9.	Piper AltiMatic IIIB-1 (Includes Roll, Pitch AutoFlite II and Pitch Trim Sections) . . . . .	41
1.	Limitations . . . . .	41
2.	Procedures . . . . .	41
3.	Performance . . . . .	46
10.	Installation of AltiMatic V F/D-1 . . . . .	47
1.	Limitations . . . . .	47
2.	Normal Operating Procedures . . . . .	47
3.	Emergency Operating Procedure . . . . .	51
4.	Placards . . . . .	51
11.	Installation of AltiMatic V-1 . . . . .	53
1.	Limitations . . . . .	53
2.	Normal Operating Procedures . . . . .	53
3.	Emergency Operating Procedure . . . . .	56
4.	Placards . . . . .	56

---

12. Installation of Piper AutoControl IIIB . . . . .	57
1. Limitations . . . . .	57
2. Procedures . . . . .	57
3. Emergency Operation . . . . .	59
4. Performance . . . . .	59
13. Installation of Piper AltiMatic IIIC (Includes Roll, Pitch and Pitch Trim Sections) . . .	61
1. Limitations . . . . .	61
2. Procedures . . . . .	61
3. Performance . . . . .	66

FAA APPROVED October 1, 1974

REPORT: 1630 PART I PAGE iii  
MODEL: PA-23-250 (Six Place)  
SN 27-4426, 27-4574 and up

THIS PAGE INTENTIONALLY LEFT BLANK

SECTION II  
LIMITATIONS

The following limitations must be observed in the operation of this airplane:

- A. ENGINE  
Lycoming IO-540 Series Two
- ENGINE LIMITS  
For all operation 2575 RPM, 250 BHP
- B. FUEL  
91/96 Octane Aviation Gasoline (Minimum)
- C. PROPELLERS  
Hartzell HC-E2YR-2 Series Two  
Constant Speed  
Full Feathering; Blades 8465-7R  
Pitch Settings at 30 in. Station  
High 80°, Low 14.5°
- D. COWL FLAPS  
Cowl flaps are provided to allow manual control of engine temperatures. The cowl flaps should be open during ground operations and in climbs. In no case should the cylinder head temperatures be allowed to exceed 500°F. and the oil temperatures allowed to exceed 245°F. On airplanes equipped with 24 volt 70 amp alternators, the cowl flaps must be full open during climbs above 18,000 ft with an alternator loaded to 60 amps or more.
- E. WING FLAPS  
Takeoff 0°  
Landing 0° to 50°
- F. INSTRUMENT MARKINGS (POWER PLANT)
- OIL TEMPERATURE
- |                                    |               |
|------------------------------------|---------------|
| Green Arc (Normal Operating Range) | 120° to 245°F |
| Yellow Arc (Caution)               | 60° to 120°F  |
| Red Line (Maximum)                 | 245°F         |
- OIL PRESSURE
- |                                    |   |
|------------------------------------|---|
| Green Arc (Normal Operating Range) | 60 PSI to 90 PSI                          |
| Yellow Arc (Caution)               | 25 PSI to 60 PSI<br>and 90 PSI to 100 PSI |
| Red Line (Minimum)                 | 25 PSI                                    |
| Red Line (Maximum)                 | 100 PSI                                   |
- TACHOMETER
- |                                    |                     |
|------------------------------------|---------------------|
| Green Arc (Normal Operating Range) | 500 RPM to 2575 RPM |
| Red Line (Maximum)                 | 2575 RPM            |
- FUEL FLOW
- |                                    |                  |
|------------------------------------|------------------|
| Green Arc (Normal Operating Range) | 0 GPH to 26 GPH  |
| Red Line (Maximum at Sea Level)    | 26 GPH (7.8 PSI) |

FAA APPROVED January 21, 1970  
REVISED: October 1, 1974

REPORT: 1630 PART I PAGE 3  
MODEL: PA-23-250 (Six Place)  
SN 27-4426, 27-4574 and up

**AZTEC "E"**

**CYLINDER HEAD TEMPERATURE**

Green Arc (Normal Range)

200° to 500° F

Red Line (Maximum)

500° F

**G. AIRSPEED LIMITATIONS AND INDICATOR MARKINGS (Calibrated Airspeed) Normal Category**

NEVER EXCEED SPEED 249 MPH  
 MAXIMUM STRUCTURAL CRUISING SPEED 198 MPH  
 DESIGN MANEUVERING SPEED 149 MPH

FLAPS EXTENDED SPEEDS 70 MPH to 125 MPH  
 Full Flap 125 MPH  
 Half Flap 140 MPH  
 Quarter Flap 160 MPH

MAXIMUM GEAR EXTENDED SPEED 150 MPH

MINIMUM CONTROL SPEED (Single Engine, 0° Flaps) 80 MPH

**STALL SPEED**

Gear and Flaps Up 76 MPH  
 Gear and Flaps Down 70 MPH

**AIRSPEED INDICATOR MARKINGS**

Green Arc (Normal Operating Range) 76 MPH to 198 MPH  
 Yellow Arc (Caution Range - Smooth Air) 198 MPH to 249 MPH  
 White Arc (Flaps Extended Range) 70 MPH to 125 MPH  
 Radial Red Line (Never Exceed - Smooth Air) 249 MPH

**H. FLIGHT LOAD FACTORS**

Positive Load Factor (Maximum) 3.68 G  
 Negative Load Factor (Maximum) No Inverted Maneuvers Approved

**I. MAXIMUM WEIGHT**

Maximum Takeoff Weight 5200 LBS  
 Maximum Landing Weight 4940 LBS  
 Maximum Zero Fuel Weight 4400 LBS

It is the responsibility of the airplane owner and the pilot to assure that the airplane is properly loaded. See "Weight and Balance Section" for proper loading instructions.

**J. C. G. RANGE**

Weight Pounds	Forward Limit Inches Aft of Datum	Aft Limit Inches Aft of Datum
5200	99.0	100.5
5000	97.0	100.5
3250	85.7	100.5

1. Straight line variation between the points given.
2. Datum is 80 inches ahead of the wing leading edge outboard of the tapered sections.

**K. MANEUVERS**

All intentional acrobatic maneuvers (including spins) are prohibited.

**L. PLACARDS**

On the instrument panel in full view of the pilot:

THIS AIRPLANE MUST BE OPERATED AS A NORMAL CATEGORY AIRPLANE IN COMPLIANCE WITH THE AIRPLANE FLIGHT MANUAL. ACROBATIC MANEUVERS (INCLUDING SPINS) PROHIBITED.

On the instrument panel:

"MINIMUM SINGLE ENGINE CONTROL SPEED 80 MPH"

Under both center windows:

"LATCH SEATS FOR TAKE-OFF AND LANDING"

On firing ring cover of emergency landing gear extender under left front seat:

"EMERGENCY GEAR EXTENDER PLACE GEAR SELECTOR TO DOWN POSITION LIFT COVER, PULL RING".

On forward baggage compartment door frame:

"BAGGAGE MAXIMUM 150 LBS. SEE LOADING SCHEDULE"

On rear baggage compartment door:

"MAXIMUM BAGGAGE 150 LBS. INCLUDES 20 LBS. ON SHELF. SEE LOADING SCHEDULE".

Inside rudder on tip rib (Ser. Nos. 27-4426, 27-4574 through 27-7305134):

"ANTI-COLLISION LIGHT REQUIRED FOR PROPER RUDDER MASS BALANCE. DO NOT REMOVE. SEE SERVICE MANUAL".

On emergency exit, middle window left side:

"EMERGENCY EXIT RELEASE: REMOVE COVER, TURN HANDLE, PUSH DOOR".

AZTEC "E"

---

On right sun visor, (Power Chart) (required on normally aspirated models only):

DO NOT EXCEED 27" MANIFOLD PRESSURE BELOW 2300  
RPM OR 25" BELOW 2000 RPM.

On instrument panel (ser. nos. 27-4426, 27-4574 thru 27-7405476):

WARNING – UNCOORDINATED MANEUVERS, INCLUDING  
SIDE SLIPS OF 30 SECONDS OR MORE, FOR ANY  
REASON, AND FAST TAXI TURNS JUST PRIOR TO  
TAKE-OFF CAN CAUSE LOSS OF POWER IF FUEL  
TANKS IN USE ARE LESS THAN 1/2 FULL

REPORT: 1630 PART I PAGE 6  
MODEL: PA-23-250 (Six Place)  
SN 27-4426, 27-4574 and up

FAA APPROVED January 21, 1970  
REVISED: March 21, 1975

SECTION III  
PROCEDURES

## A. SYSTEMS OPERATION AND CHECKS

1. VOLTAGE REGULATING AND ALTERNATOR SYSTEM (FOR AIRCRAFT UP TO AND INCLUDING SERIAL NO. 27-4793)

## a. Alternator System

A three position selector switch is provided to check the current output of each alternator and current to the battery. A preflight check should be made as follows: Run up engines to 1200 RPM. With selector switch in "BAT" position should show charge. "LT ALT" and "RT ALT" will show the actual output of the respective alternator. The alternator outputs should be approximately equal.

## b. Voltage Regulating System

In event of failure of the voltage regulating system an auxiliary regulating system may be switched into the circuit. Abnormal operation may be indicated by zero output on both alternator test positions and a discharge indication for battery. To energize the auxiliary regulating system the following procedure shall be followed:

- (1) Reduce aircraft electrical load to minimum for continued safe flight.
- (2) Switch "VOLTAGE REGULATOR SELECTOR" to "AUX" position.
- (3) Reset tripped breakers but do not reset "MAIN" Voltage Regulator Breaker.
- (4) Return to normal required electrical load.

If the electrical system still fails to maintain correct output while using the AUX. VOLTAGE REGULATOR system, an alternator failure has probably occurred. To isolate the faulty component the following procedure should be followed:

- (1) Reduce aircraft electrical load to minimum for continued safe flight.
- (2) Turn aircraft MASTER SWITCH "OFF."
- (3) Place both alternator output circuit breaker switches "OFF."
- (4) Reset both MAIN and AUX. Voltage Regulator Circuit Breakers, if tripped. Return Voltage Regulator Selector to "MAIN."
- (5) Turn aircraft MASTER SWITCH "ON." Reset Voltage Regulator Circuit Breaker, if tripped.
- (6) Close one alternator output circuit breaker switch. Observe if electrical system is operating normally by checking for alternator output current on the ammeter. If not operating properly, open the alternator output circuit breaker; turn aircraft MASTER SWITCH "OFF" for approximately six seconds to reset the overvoltage relay.
- (7) Turn aircraft MASTER SWITCH "ON." Reset Voltage Regulator Circuit Breaker, if tripped. Close other alternator output circuit breaker switch and observe if electrical system is operating normally by checking ammeter indication as above.
- (8) Check that aircraft electrical load does not exceed the output capability of the operating alternator causing the battery to discharge.

## CAUTION

Use of the voltage regulator selector switch and alternator circuit breakers should be limited to the above conditions.



## 2. ALTERNATOR PARALLELING SYSTEM (FOR AIRCRAFT SER. NO. 27-4794 AND UP)

On aircraft equipped with the subject system, each alternator is controlled independently by its own voltage regulator. These regulators are interconnected electronically so as to provide paralleled outputs from their associated alternators under normal operating engine RPM ranges. An ammeter that can be switched into either alternator output lead is provided for system monitoring, along with alternator "INOP" warning lights that illuminate when their associated alternator is not producing a voltage.

In the event of an alternator "INOP" indication the following steps should be taken:

- a. Reduce electrical load to minimum for continued safe flight.
- b. Turn OFF one section of the Master Switch (L or R, as appropriate) to open the corresponding alternator field circuit. Reset all circuit breakers which may have tripped.
- c. Turn ON the section of the Master Switch which had been previously turned OFF and if "INOP" light goes out - reinstate electrical load.
- d. If, after turning ON the section of the Master Switch, the "INOP" light remains lit and/or the alternator circuit breaker switch has tripped, turn the same section of the Master Switch OFF and continue flight with reduced electrical load.
- e. In the event that both alternator "INOP" lights come on simultaneously, repeat the above procedure for each alternator individually.
- f. If both alternators fail to return to normal operation, turn ON Master Switch and turn OFF both alternator circuit breaker switches. Terminate flight as soon as possible.

### CAUTION

The alternator circuit breaker switches should not be opened manually whenever the alternators are functioning normally.

## 3. FUEL MANAGEMENT

- a. Normal Operation
  - (1) Take-off and landing
    - (a) Main fuel valve "ON"
    - (b) Pressure crossfeed "OFF"
    - (c) Electric fuel pumps "ON"
  - (2) Cruise
    - (a) Main fuel valves "ON"
    - (b) Pressure crossfeed "OFF"
    - (c) Electric fuel pumps "OFF"
- b. Emergency Operation - Extended Cruise
  - Single Engine
    - (1) Cruise
      - (a) A pressure crossfeed valve is provided to increase range during single engine operation. Fuel system management should be as follows:
        - (1) Pressure crossfeed "ON".
        - (2) Main fuel valve of inoperative engine "ON".
        - (3) Electric fuel pump of inoperative engine "ON".
        - (4) Main fuel valve of operating engine "OFF".
        - (5) Electric fuel pump of operating engine "OFF".

(b) When fuel from the cell of the inoperative engine is exhausted return to the operating engine fuel system as follows:

- (1) Main valve operating engine "ON".
- (2) Electric pump operating engine "ON".
- (3) Electric pump inoperative engine "OFF".
- (4) Pressure crossfeed "OFF".
- (5) Main valve inoperative engine "OFF".
- (6) Electric pump operating engine "OFF".

(2) Landing

- (a) Main valve "ON" on operative engine.
- (b) Pressure crossfeed "OFF".
- (c) Electric fuel pump "ON" on operative engine.
- (d) Inoperative engine fuel valve "OFF".
- (e) Inoperative engine electric fuel pump "OFF".

#### 4. LANDING GEAR AND FLAP EXTENSION - EMERGENCY

a. In case of hydraulic pump failure, landing gear and flap extension may be accomplished through the use of the emergency hand pump by placing the pertinent selector handle in the down position and operating the manual pump as follows:

- (1) Pull emergency pump handle out as far as possible.
- (2) Pump handle up and down until pressure is built up in the system and the selector handle automatically returns to neutral.

The hand pump is designed to be used for emergency only.

b. Gear Extension Only with CO<sub>2</sub>:

**USE ONLY IF THE ENGINE DRIVEN AND HAND HYDRAULIC PUMPS FAIL TO EXTEND THE LANDING GEAR.**

In case the engine driven and emergency hand hydraulic pumps fail to lower the landing gear the emergency CO<sub>2</sub> system should be used as follows:

- (1) Place the gear selector handle in the down position.
- (2) Raise firing ring cover under the left front seat.
- (3) Pull ring as far as possible.

#### NOTE

After operating the CO<sub>2</sub> system the landing gear (or flap) should NOT be operated and the selector handles should NOT be moved until repairs are made to the system. See Service Manual for repair procedure.

#### 5. STALL WARNING INDICATOR

The stall warning system is inoperative with the master switch "OFF".

AZTEC "E"

---

THIS PAGE INTENTIONALLY LEFT BLANK.

REPORT: 1630 PART I PAGE 10  
MODEL: PA-23-250 (Six Place)  
SN 27-4426, 27-4574 and up

FAA APPROVED January 21, 1970

## B. EMERGENCY PROCEDURES

### 1. FEATHERING PROCEDURE

Open operative engine throttle to maintain altitude and airspeed. MAINTAIN AT LEAST 102 MPH (BEST SINGLE RATE OF CLIMB).

Inoperative engine procedure is as follows:

- a. "CLOSE" throttle.
- b. Prop control "FEATHERED". PROPELLER CANNOT BE FEATHERED UNDER 1000 RPM.
- c. Mixture control "IDLE CUT-OFF".
- d. Ignition switches "OFF".
- e. Electric fuel pump "OFF".
- f. Main fuel valve "OFF" inoperative engine side.

### 2. UNFEATHERING PROCEDURE

The procedure to unfeather a propeller is as follows:

- a. Turn main fuel valve "ON."
- b. Turn ignition switches "ON."
- c. Prime engine if necessary, then turn electric fuel pump off.
- d. Open throttle 1/2 inch.
- e. Advance propeller control to high RPM position.
- f. Advance mixture control to full rich.
- g. Engage starter.
- h. As RPM passes 1000 coming out of feather, retard propeller control to maintain 1800-2000 RPM for warm-up. Adjust manifold pressure to 15" and maintain this low power until oil temperature begins to rise and oil pressure can be maintained within limits.
- i. Re-synchronize engines.

### 3. EMERGENCY EXIT

Emergency Exit from the aircraft may be made through the Emergency Exit, middle window, on the left side of the cabin. The exit is operated by removing the plastic handle guard and twisting the handle rearward. The window may then be pushed outward away from the fuselage.

APPROVED January 21, 1970  
REVISED: October 1, 1974

REPORT: 1630 PART I PAGE 11  
MODEL: PA-23-250 (Six Place)  
SN 27-4426, 27-4574 and up

AZTEC "E"

---

THIS PAGE INTENTIONALLY LEFT BLANK.

REPORT: 1630 PART I PAGE 12  
MODEL: PA-23-250 (Six Place)  
SN 27-4426, 27-4574 and up

FAA APPROVED January 21, 1970

SECTION V  
SUPPLEMENTS

## NOTE

A FLIGHT MANUAL SUPPLEMENT IS REQUIRED TO BE IN THE AIRPLANE FLIGHT MANUAL ONLY IF THE EQUIPMENT WHICH IS THE SUBJECT OF THE SUPPLEMENT IS INSTALLED.

1. Icing Equipment Installation
2. Oxygen System Installation
3. Installation of Piper AutoControl III
4. Installation of Lycoming Turbocharged Engines
5. Installation of Piper AltiMatic IIIB
6. Installation of Anti-Collision (Strobe) Lights
7. Installation of AltiMatic V F/D
8. Installation of AltiMatic V
9. Piper AltiMatic IIIB-1 (Includes Roll, Pitch, AutoFlite II and Pitch Trim Sections.)
10. Installation of AltiMatic V F/D-1
11. Installation of AltiMatic V-1
12. Installation of Piper AutoControl IIIB
13. Installation of Piper AltiMatic IIIC (Includes Roll, Pitch and Pitch Trim Sections)

FAA APPROVED January 21, 1970  
REVISED: October 1, 1974

REPORT: 1630 PART I PAGE 15  
MODEL: PA-23-250 (Six Place)  
SN 27-4426, 27-4574 and up

AZTEC "E"

---

THIS PAGE INTENTIONALLY LEFT BLANK.

REPORT: 1630 PART I PAGE 16  
MODEL: PA-23-250 (Six Place)  
SN 27-4426, 27-4574 and up

FAA APPROVED January 21, 1970

## 1. ICING EQUIPMENT INSTALLATION

1. The following items of equipment must be installed and operable to effectively cope with normally encountered icing conditions:
  - a. B. F. Goodrich Wing and Tail Pneumatic Deicing Boots installed per B. F. Goodrich S.T.C. No. SA155EA, revised March 6, 1970, or FAA approved equivalent, or Piper Drawing No. 32735, or 32302. (Ref. Item 503 (b), or 503 (c), Aircraft Specification No. 1A10.)
 

or

 B. F. Goodrich Wing and Tail Pneumatic Deicing Boots Installed per B. F. Goodrich S.T.C. No. SA155EA, revised September 30, 1974, and Piper Drawing No. 33435-3.
 

or

 Airborne Mfg. Co. Wing and Tail Pneumatic Deicing Boots Installed per Airborne S.T.C. SA667CE, revised March 14, 1975 and Piper Drawing No. 15695-2.
  - b. B. F. Goodrich Electric Propeller Deicing Installed per B. F. Goodrich S.T.C. No. SA195EA, dated June 24, 1964, or FAA approved equivalent or Piper Drawing No. 32740. (Ref. Item 504 (b), Aircraft Specification No. 1A10.)
  - c. Piper Antennas Installed per P.A.C. Dwg. 31628. No special operating instructions required.
  - d. Piper Heated Glass Panel on Windshield Installed per P.A.C. Dwg. 31640. (Ref. Item 502 (b), Aircraft Specification No. 1A10.)
  - e. Heated Pitot Head per P.A.C. Dwg. 19024. No special operating instructions required. (Ref. Item 601, Aircraft Specification No. 1A10.)

## 2. PLACARDS

- a. At switch:
 

W'SHIELD  
HEAT
- b. At circuit breaker:
 

W'SHIELD  
HEAT
- c. When any of the above icing equipment is not installed, the following placard must be on the instrument panel:  
"Warning - This aircraft is not fully equipped for flight in icing condition."

### NOTE

WHEN ALL ITEMS OF EQUIPMENT LISTED ABOVE ARE INSTALLED, PLACARD NO. c. IS NOT REQUIRED.

## 3. OPERATING INSTRUCTIONS

- a. Heated Windshield
  - (1) Prior to flight in conditions where the possibility of encountering icing exists, the HEATED PANEL assembly should be attached to the aircraft and the lead wire plug firmly inserted in socket provided.

FAA APPROVED January 21, 1970  
REVISED: May 12, 1975

REPORT: 1630 PART I PAGE 17  
MODEL: PA-23-250 (Six Place)  
SN 27-4426, 27-4574 and up



- (2) An operational check should then be accomplished by turning the HEATED PANEL switch ON for a period not exceeding 30 SEC.
- (3) Proper operation is indicated by the glass section being warm to the touch.
- (4) If icing conditions are encountered the HEATED PANEL switch should be turned ON and remain ON until the icing conditions cease.
- (5) When icing is not prevalent the unit should be turned OFF. UNDER NO CIRCUMSTANCE SHOULD THE UNIT BE TURNED ON FOR A PERIOD EXCEEDING 30 SEC. UNLESS:
  - (a) The aircraft is in flight, or
  - (b) Ice exists on the HEATED PANEL.

#### CAUTION

This equipment cannot be expected to cope with heavy or very prolonged moderate icing conditions. The latter can be expected to tax the equipment beyond its capacity.

Pilots should always strive to avoid heavy icing conditions. If heavy icing is encountered unexpectedly or unavoidably, prompt action must be taken to get into more favorable flying weather conditions.

#### NOTE

When all items of equipment listed above are installed, the B. F. Goodrich placard "Warning - This aircraft is not fully equipped for flight in icing conditions." IS NOT REQUIRED. When the heated panel is removed or any of the above listed installed equipment is inoperable (known before flight) the warning placard must be reinstalled.

#### b. Pneumatic Deicing System

##### (1) Operating Procedures

##### (a) Preflight Check

1. Check wing deice indicator (press-to-test).
2. Check source indicator for pump malfunction.
3. At approximately 2000 RPM, check the deicer operation. Actuate wing deice switch. In approximately three seconds the indicator light will glow, indicating inflation. Also check the deicer boots visually.

##### (b) Normal Operation

1. Light Icing - Actuate wing deice switch. Boots will complete one inflation cycle. Wing deice indicator will glow during the six-second inflation period. Most effective deicing is obtained if a thickness of 1/4 to 1/2" of ice is collected before the deicers are operated.
2. Heavier Icing - The wing deice switch will permit the operator to manually cycle the system at any desired time interval, should icing conditions require.

#### NOTE

With both engines at 2000 RPM and all other system checks normal, a time between boot actuation and indicator light illumination exceeding 4 seconds indicates a leak in the system.

## (2) Altitude Limitations on Deicer Boots

The deicer boots have been tested and approved for all altitudes up to and including 24,000 feet with the following limitations in icing conditions:

No. of Pneumatic Pumps	Engine Speed RPM	Altitude	Max. Altitude for Optimum Boot Effectiveness
2	2200	20,000 ft. and below	20,000 ft.
2	2575	Above 20,000 ft.	24,000 ft.
1	2575	All altitudes	15,000 ft.

FAA APPROVED October 1, 1974

REPORT: 1630 PART I PAGE 18a  
MODEL: PA-23-250 (Six Place)  
SN 27-4426, 27-4574 and up

AZTEC "E"

---

THIS PAGE INTENTIONALLY LEFT BLANK

REPORT: 1630 PART I PAGE 18b  
MODEL: PA-23-250 (Six Place)  
SN 27-4426, 27-4574 and up

FAA APPROVED October 1, 1974

## 2. OXYGEN SYSTEM INSTALLATION

### 1. LIMITATIONS

No smoking while the oxygen system is in use.

### 2. PROCEDURES

a. Check pressure gauge in rear of cabin for sufficient pressure for anticipated requirements for flight. Full system pressure is approximately 1850 PSIG. If necessary recharge cylinder.

b. When oxygen is desired pull out control cable knob placing regulator in "ON" position.

c. At seating positions where oxygen is to be used plug mask assembly into oxygen outlet, turn clockwise 90°, and apply mask to face.

d. The flow indicator located in the mask assembly oxygen line should be checked. When red indicator disappears the oxygen is flowing through the line normally.

e. To stop flow of oxygen push in control cable knob placing regulator in "OFF" position and remove mask from face.

f. Leave mask assembly connected to oxygen outlet for at least 3 minutes to completely bleed down low pressure lines.

### 3. PLACARDS

a. At each oxygen outlet:

NO SMOKING WITH OXYGEN IN USE

b. At the oxygen control knob:

PULL ON, PUSH OFF, OXYGEN

c. On rear baggage door:

MAXIMUM BAGGAGE 105 LBS.  
INCLUDES 20 LBS. ON SHELF  
SEE LOADING SCHEDULE

### 4. EMERGENCY

In the event that during operation the red indicator appears in any of the flow indicators, the aircraft should be lowered to a safe altitude immediately.

FAA APPROVED January 21, 1970  
REVISED: February 1, 1971

REPORT: 1630 PART I PAGE 19  
MODEL: PA-23-250 (Six Place)  
SN 27-4426, 27-4574 and up

THIS PAGE INTENTIONALLY LEFT BLANK.

REPORT: 1630 PART I PAGE 20  
MODEL: PA-23-250 (Six Place)  
SN 27-4426, 27-4574 and up

FAA APPROVED January 21, 1970

### 3. INSTALLATION OF PIPER AUTOCONTROL III

#### 1. LIMITATIONS

Disengage during takeoff and landing.

#### 2. OPERATING INSTRUCTIONS

##### To Engage:

Push Console Heading Lock Button (HDG) to "OFF" position. Center ROLL knob. Push ON/OFF button to "ON" position.

##### To Turn:

Rotate console ROLL knob in desired direction.

##### For Heading Lock:

Set directional gyro (D.G.) with magnetic compass. Push D.G. HDG knob in, rotate to select desired heading. Push console Heading Lock button (HDG) to "IN" position.

##### To Disengage:

Push ON/OFF button to "OFF" position.

#### 3. NORMAL OPERATION

- a. Be sure airplane is properly trimmed. (Ball Centered)
- b. Check vacuum and ascertain that the directional gyro and artificial horizon are functioning properly.
- c. Engage AutoControl.
- d. (Ground Check Only) Rotate the ROLL knob full right and full left. Determine that the control wheel describes a corresponding right and left turn, then center knob.
- e. Set the directional gyro with the magnetic compass. Push D.G. HDG knob in, rotate to select desired heading.
- f. Push Console Heading Lock button to "IN" position. The AutoControl is now "locked-in" for directional control.
- g. Turns may be accomplished by either of the following methods:
  - (1) Push Console Heading Lock button to "OUT" position. Rotate the ROLL knob in desired direction.
  - (2) Push Console Heading Lock button to "IN" position. Select new heading by pushing D.G. HDG knob in and rotating.
- h. Maximum angle of bank should not exceed 20°.
- i. Disengage AutoControl by pushing the ON/OFF button to "OFF" position.

##### With Piper Radio Coupler Installed:

The AutoPilot is coupled to the VOR NAV receiver in the modes indicated on the function switch.

In the Heading (HDG) mode, the AutoPilot is controlled by the directional gyro.

#### 4. EMERGENCY PROCEDURES

- a. In the event of a malfunction in the AutoControl, push the ON/OFF button to "OFF" position. This disengages the AutoControl from the control system.
- b. AutoControl may be overpowered manually by exertion of 12 ( $\pm$  3) pounds force on the control wheel.

FAA APPROVED January 21, 1970  
REVISED: February 1, 1971

REPORT: 1630 PART I PAGE 21  
MODEL: PA-23-250 (Six Place)  
SN 27-4426, 27-4574 and up

c. In cruise configuration AutoControl malfunction with a 3 second recovery delay resulted in a 32° bank and 100 foot altitude loss.

d. In approach configuration AutoControl malfunction with a 1 second recovery delay resulted in a 15° bank and 50 foot altitude loss.

## 4. INSTALLATION OF LYCOMING TURBOCHARGED ENGINES

1. LIMITATIONS

The following limitations must be observed in the operation of this airplane:

- a. Engine  
Two Lycoming TIO-540-C Series
- b. Engine Limits  
250 HP at 2575 RPM. Do not exceed 39.5 in. Hg. manifold pressure at or below 18,500 ft. MSL. Do not exceed 21.0 in. Hg. manifold pressure at 30,000 ft. MSL. Straight line variation between points given.
- c. Fuel  
100/130 min. grade aviation gasoline
- d. Propeller  
Two Hartzell Model HC-E2YR-2 Series Constant Speed Full Feathering with 8465-7R blades. Pitch settings at 30 in. station: Low 15.2°, High 80°.
- e. Cowl Flaps  
Cowl Flaps will be positioned to maintain temperatures at or below maximum temperature.
- f. Instrument Markings (Power Plant)  
Fuel Flow: Green Arc (Normal Operating Range) 0 to 32.0 G.P.H. Red Line (Maximum at Sea Level) 32.0 G.P.H. (14.0 psi)  
Exhaust Gas Temperature: Green Arc (Normal Operating Range) Zero or lower scale limit to 1650°F. Radial Red Line (Never Exceed) 1650°F.  
Manifold Pressure: Radial Red Line (Never Exceed) 39.5 inches.
- g. Airspeed Limits  
Above 21,000 feet reduce Vne speed 5 MPH per 1,000 feet.
- h. C. G. Range\*

Weight Pounds	Forward Limit Inches Aft of Datum	Aft Limit Inches Aft of Datum
5200	99.0	100.5
5000	95.6	100.5
4630	93.0	100.5
3250	85.7	100.5

1. Straight line variation between the points given.
2. Datum is 80 inches ahead of the wing leading edge outboard of the tapered sections.

\*Applicable only for serial no. 27-4781 and subsequent, or for serial no. prior to 27-4781 if service kit 760 587 has been installed.

FAA APPROVED January 21, 1970  
REVISED: March 21, 1977

REPORT: 1630 PART I PAGE 23  
MODEL: PA-23-250 (Six Place)  
SN 27-4426, 27-4574 and up



i. Placards

On the instrument panel "Above 21,000 feet reduce Vne speed 5 MPH per 1,000 feet."

j. Maximum Weight

Maximum Zero Fuel Gross Weight, 4500 lbs.

2. NORMAL OPERATING PROCEDURES

a. Under full throttle operations (such as take-off and climb) the engines of this aircraft have been adjusted to provide 33.0 in. Hg. of manifold pressure at sea level and standard temperature. It is possible to read higher (up to 39.5 inches of manifold pressure) or lower than 33.0 inches of manifold pressure when ambient temperatures are higher or lower than standard.

b. The engines of this airplane are equipped with dynamic counterweight systems. Therefore, avoid rapid closing or opening of the throttle in order to prevent severe damage which could cause malfunction.

c. When increasing power, increase engine speed prior to manifold pressure. When decreasing power, decrease manifold pressure before engine speed.

d. See Lycoming Instructions for leaning procedure.

3. PERFORMANCE

Loss of altitude during a multi-engine power-on stall with gear and flaps retracted is 500 feet. Other stall configurations result in less loss of altitude.

## 5. INSTALLATION OF PIPER ALTIMATIC IIIB

### 1. LIMITATIONS

ROLL and PITCH off during take-off and landing.

### 2. OPERATING INSTRUCTIONS

#### a. ROLL SECTION

##### To Engage:

Push console heading lock button (HDG) "OFF". Center ROLL knob. Push rocker switch to "ON" position.

##### To Turn:

Rotate console ROLL knob in desired direction. (Maximum angle of bank should not exceed 30°. Maximum angle will be 20° with heading lock engaged.)

##### Heading Lock:

Set directional gyro with magnetic compass. Push directional gyro HDG knob in, rotate to select desired heading. Push console heading lock button (HDG) to "ON" position.

##### Roll Section Ground Check:

With heading lock button "OFF", engage ROLL SECTION and rotate ROLL knob full right and full left. Determine that the control wheel describes a corresponding right and left turn, then center knob and disengage prior to take-off.

#### b. PITCH SECTION (ROLL SECTION must be engaged prior to engaging PITCH SECTION.)

##### To Engage:

Push Altitude preselect button (ALT) to "OFF" position. Center the PITCH command disk. Push PITCH button to "ON" position.

##### To Change Altitude:

Rotate PITCH command disk in desired direction.

##### Altitude Preselect:

Center PITCH command disk. With airplane in level flight, rotate the altitude selector DN/UP knob until trim UP/DN indicator is level. Calibrate the altitude indicator to match altimeter by rotating the knurled altitude indicator dial. Rotate the altitude selector knob to select desired altitude. Push altitude preselect button (ALT) to "ON" position.

The altitude preslect button may also be engaged when the aircraft is climbing or descending. Rotate the altitude selector knob until trim indicator indicates UP or DOWN as desired, then engage the altitude preselect button.

##### Pitch Section Ground Check:

With altitude preslect button "OFF", rotate the PITCH command disk full DOWN and full UP. Determine that the control wheel describes a corresponding fore and aft movement, then center the disk and disengage prior to take-off.

c. AUTOFLITE SECTION

The AUTOFLITE SECTION of the Altimatic IIIB is approved for full time use, including take-off and landing. The engagement of the ROLL SECTION automatically disengages the AUTOFLITE SECTION.

To Engage:

Place AUTOFLITE rocker switch in "ON" position. Correct minor heading variation by rotating AUTOFLITE "TRIM" knob in desired direction.

To Turn:

Push AUTOFLITE "OFF" button on control wheel. Make turn manually. Release button to re-engage AUTOFLITE on completion of turn.

d. PITCH TRIM SECTION

The airplane can be trimmed (1) manually with the crank or (2) by actuating the pitch trim slide switch on the pilot's control wheel. Push switch forward for nose down trim and rearward for nose up trim. Pitch trim is automatically accomplished when the PITCH SECTION is engaged.

With Pitch Trim Warning Light Installed:

The warning light on the instrument panel will light when the pitch is out of trim for approximately 4 seconds, when the pitch section is engaged.

The press-to-test feature of the indicator light assembly, when held in (with autopilot pitch function engaged) will show the operator that the lamp is good and the length of time that is required for the warning system to actuate.

With Piper Radio Coupler Installed:

The ALTIMATIC is coupled to the VOR NAV receiver in the modes indicated on the function switch.

In the heading (HDG) mode, the ALTIMATIC is controlled by the directional gyro.

With Piper Glide Slope Coupler Installed:

To engage glide slope coupler

- a. Set radio coupler to localizer normal mode (LOC/NORM).
- b. Engage altitude hold.
- c. Extend landing gear (approach to be made with zero flap).
- d. Adjust power to maintain desired approach speed (120 MPH minimum).

3. NORMAL FLIGHT OPERATION

- a. Be sure airplane is properly trimmed. (Ball Centered)
- b. Engage AUTOFLITE SECTION.
- c. Check vacuum and ascertain that the directional gyro and artificial horizon are functioning properly.
- d. Engage ROLL SECTION.
- e. Engage PITCH SECTION.
- f. Disengage ROLL and PITCH SECTIONS before landing.

4. EMERGENCY PROCEDURES

a. In the event of a malfunction in the ROLL or PITCH SECTION, push the ROLL ON/OFF button "OFF", or push the A/P "OFF" button on the control wheel.

Either operation above disengages both ROLL and PITCH SECTIONS of the ALTIMATIC from the control system and will disengage the AUTOFLITE SECTION if engaged, as long as button remains depressed.

After the A/P "OFF" button on the control wheel has been pushed due to a malfunction in the ROLL or PITCH SECTION, the ALTIMATIC IIIB can only be re-engaged by the actuation of the ROLL rocker switch and PITCH button on the console.

AUTOFLITE SECTION will automatically re-engage upon release of the A/P button.

b. The PITCH TRIM SECTION may be overpowered manually. In the event of a malfunction in the PITCH TRIM SECTION, pull the Pitch Trim circuit breaker.

c. The Altimatic ROLL SECTION and AUTOFLITE SECTION and PITCH SECTION may be overpowered manually by either control wheel.

d. In cruise configuration, Altimatic malfunction with a 3 second recovery delay results in a 32° bank and 200 foot altitude loss.

e. In approach configuration, Altimatic malfunction with a 1 second recovery delay results in a 15° bank and 50 foot altitude loss.

f. In cruise configuration, AUTOFLITE malfunction with a 3 second recovery delay results in a 32° bank and a 25 foot altitude loss.

g. In approach configuration, AUTOFLITE malfunction with a 1 second recovery delay results in a 15° bank and a 50 foot altitude loss.

5. PLACARDS

a. On left control wheel:

DWN UP

b. On left control wheel:

A/P OFF

c. On instrument panel:

AUTOFLITE  
TRIM  
L R

d. On instrument panel (when radio coupler is installed):

A/P NAV SEL  
ON  
OFF  
ON

e. On instrument panel (when glide slope coupler is installed):

G/S  
ENGAGED

f. On instrument panel (when pitch trim warning is installed):

PITCH  
OUT OF TRIM

AZTEC "E"

---

THIS PAGE INTENTIONALLY LEFT BLANK.

REPORT: 1630 PART I PAGE 28  
MODEL: PA-23-250 (Six Place)  
SN 27-4426, 27-4574 and up

FAA APPROVED January 21, 1970

## 6. INSTALLATION OF ANTI-COLLISION (STROBE) LIGHTS

1. OPERATING LIMITATIONS

## Placards:

a. On left window moulding in full view of the pilot when RED anti-collision (Strobe) lights are installed:

WARNING  
TO AVOID OPTICAL ILLUSION AND SEVERE VERTIGO.  
TURN ANTI-COLLISION LIGHTS OFF UPON ENTERING  
CLOUDS, FOG OR HAZE.

b. On left window moulding in full view of the pilot when supplementary WHITE anti-collision (Strobe) lights are installed: (Serial Nos. up to and including 27-7554041)

WARNING  
TURN OFF STROBE LIGHTS WHEN TAXIING IN VICINITY  
OF OTHER AIRCRAFT, OR DURING FLIGHT THROUGH  
CLOUD, FOG OR HAZE.

STANDARD POSITION LIGHTS TO BE ON FOR ALL NIGHT  
OPERATIONS.

c. On left window moulding in full view of the pilot when supplementary WHITE anti-collision (Strobe) lights are installed: (Serial Nos. 27-7554042 and up)

WARNING  
TURN OFF ANTI-COLLISION LIGHTS WHEN TAXIING IN  
VICINITY OF OTHER AIRCRAFT, OR DURING FLIGHT  
THROUGH CLOUD, FOG OR HAZE.

STANDARD POSITION LIGHTS TO BE ON FOR ALL NIGHT  
OPERATIONS.

FAA APPROVED January 21, 1970  
REVISED: March 20, 1979

REPORT: 1630 PART I PAGE 29  
MODEL: PA-23-250 (Six Place)  
SN 27-4426, 27-4574 and up

THIS PAGE INTENTIONALLY LEFT BLANK.

## 7. INSTALLATION OF ALTIMATIC V F/D

## NOTE

The maximum altitude for operation of the AutoPilot has not been determined. The maximum altitude demonstrated during flight tests was 24,000 feet.

## 1. LIMITATIONS

- a. AutoPilot OFF during take-off and landing.
- b. Do not engage AutoPilot if airplane is out of trim.
- c. Maximum airspeed for AutoPilot operation is 240 mph (209 kts) CAS.
- d. During Flight Director/AutoPilot operation, the pilot must be in his seat with the safety belt fastened.
- e. Do not manually override AutoPilot to produce or prevent pitch attitude changes or to increase bank angle.
- f. During AutoPilot operation, the wing flaps must be fully retracted.

## 2. NORMAL OPERATING PROCEDURES

- a. FD/AP MASTER SWITCH - Turn the FD/AP Master Switch to "ON".
- b. The Flight Director incorporates a Director Horizon in lieu of the conventional Artificial Horizon. In addition to supplying attitude information to the computer, the Director Horizon displays command dots which receive information from the computer in the same manner as the AutoPilot servos. By maneuvering the aircraft to satisfy the command dots, the pilot is acting in the same manner as the AutoPilot servos.
- c. Adjust pitch command to align the command dots with the simulated red tip tanks of the Director Horizon.
- d. BEFORE TAKE-OFF - Engage the AutoPilot, apply a force to the controls (on one axis at a time) to determine if the AutoPilot may be overpowered.
  - (1) Press HDG, NAV, APPR, REV buttons one at a time, place pitch command disk in center detent position and check respective lights on the Flight Controller for operation.
  - (2) Disengage the AutoPilot and recheck aircraft pitch trim before take-off.
- e. PITCH TRIM INDICATOR - Centering the Pitch Trim Indicator (by rotating the pitch command) prior to engagement will insure that the aircraft will continue in its present attitude. However, if the Trim Indicator is not centered, aircraft will smoothly take up the attitude dictated by the pitch command.
- f. RELEASE SWITCH - The AutoPilot Release Switch is located on the left side of the pilot's control wheel. Momentarily pressing this switch disengages the AutoPilot.
- g. ENGAGE BUTTON - This button is located on the left side of the AutoPilot Controller. Manually adjust aircraft trim prior to engaging AutoPilot. Place aircraft in WINGS-LEVEL attitude. Press the ENGAGE BUTTON which will light upon engagement.
  - (1) To climb, rotate the Pitch Command Disk to UP. To descend, rotate the Pitch Command Disk to DN. The change in pitch ANGLE is determined by the amount of rotation of the pitch command disk.
  - (2) To make turns, use heading mode. See Step k.

FAA APPROVED April 15, 1970  
 REVISED: February 1, 1971

REPORT: 1630 PART I PAGE 31  
 MODEL: PA-23-250 (Six Place)  
 SN 27-4426, 27-4574 and up



h. AUTOMATIC PITCH TRIM is provided whenever the AutoPilot is engaged. Any attempt to overpower the AutoPilot pitch axis will cause the pitch trim to oppose the applied force, resulting in an out-of-trim condition and high stick forces.

To manually operate the elevator trim tab, the AutoPilot must be disengaged. Pushing the RELEASE switch will disengage the AutoPilot.

i. MANUAL ELECTRIC TRIM is provided as standard equipment with the PIPER ALTIMATIC V F/D installation. The following operating instructions apply:

#### General

The manual electric trim system is powered through the aircraft Master Switch which must be on for electric trim operation. A circuit breaker located on the circuit breaker panel provides circuit protection. Electric trim is obtained by actuating the Electric Trim Switch on the pilot's control wheel in the desired direction. During normal A/P operations, actuations of the trim switch in either direction disconnects A/P and electric trim is immediately available. A system fault or malfunction will be indicated by the trim warning light, but trim will not run away (see emergency procedures).

#### Emergency Procedures

In the event of an in-flight malfunction of the electric trim system, disconnect by pulling electric trim circuit breaker.

#### Pre-Flight

The following pre-flight shall be conducted prior to each flight and during flight as considered appropriate.

- (1) FD/AP Master Switch - ON
- (2) Trim Warning Light - OUT
- (3) Manual Trim Crank Freedom of Movement - Check
- (4) Actuate Electric Trim Slide Switch and observe proper direction of movement of manual trim crank - Check
- (5) Press the press-to-test button next to the trim warning light. Light should light while being pressed and trim should not run - Check.

#### j. AUTOMATIC ALTITUDE CONTROLLER

- (1) Altitude control is automatically engaged when the pitch command disk is in the center detent position unless the altitude control disable switch on the front of the flight controller is pulled.
- (2) Rotating the pitch command disk from detent position disengages altitude control and glide slope.
- (3) When pitch command disk is in center detent position, ALT light on flight controller will light.

#### NOTE

The altitude controller attempts to maintain the aircraft at the selected altitude by changing the pitch attitude of the aircraft. The human pilot must then maintain power settings to assure a safe airspeed.

k. **HEADING SELECTOR** - The heading knob on the Horizontal Situation Display may be used to select any heading prior to pushing the (HDG) heading engage button. When the heading engage button is pressed, the command dots will command the direction and attitude to satisfy the heading command, the aircraft will turn to the selected heading in the direction which is less than  $180^\circ$ , and at a bank angle of no more than  $25^\circ$ , and HDG light on the heading button will light.

l. **OMNI BEARING SELECTOR** - There are two methods of intercepting a VOR.

- (1) **Variable Intercept Angle** - With this method, the pilot may preselect any intercept angle desired.
  - (a) After identifying desired OMNI station, select desired OMNI course on the Horizontal Situation Display by rotating the CRS knob on the HSD until the course arrow aligns with the desired OMNI course.
  - (b) Position the Heading Select Pointer (heading bug) in the quadrant toward the Lateral Deviation Needle (left/right needle) and select the desired intercept angle by rotating the HDG knob on the Horizontal Situation Display. The number of degrees between the Course Arrow and the Heading Select Pointer is the intercept angle. For obvious reasons the pilot should not select an intercept angle less than  $20^\circ$  or more than  $90^\circ$ .
  - (c) Simultaneously press HDG and NAV buttons on the controller. HDG and NAV buttons will light. Aircraft will turn toward the heading selected until the Lateral Deviation Needle moves approximately one dot away from full deflection. At this time, the HDG button light on the controller will go out and the aircraft will assume an automatic  $45^\circ$  intercept angle.
- (2) **Fixed Intercept Angle**
  - (a) After identifying the desired OMNI station, select desired OMNI course on the Horizontal Situation Display by rotating the CRS knob on the HSD until the course arrow aligns with the desired OMNI course.
  - (b) Press the NAV button. Button light comes on. Aircraft will turn left or right, depending upon the relation of the aircraft heading to that of the selected OMNI heading. If the OMNI bearing selected is less than  $120^\circ$  from the aircraft heading when the NAV mode is selected, the aircraft will turn toward the selected OMNI course. At angles of  $120^\circ$  or greater, the aircraft will turn away from the selected OMNI course and continue to turn through the larger angle until a proper intercept course is established. In either case, the aircraft will assume an intercept course which will be no greater than  $45^\circ$  to the selected OMNI course.

m. **AUTOMATIC APPROACH COUPLER**

#### NOTE

Coupled approaches must be conducted with the wing flaps fully retracted.

- (1) As in the case of the NAV mode, there are two methods of intercepting the localizer.
  - (a) **Variable Intercept Angle** - This method is very handy when being vectored toward the localizer, by approach control, with the Headings and APPR modes engaged.
    - (1) Align Course Arrow to the published inbound course by rotating the CRS knob on the HSD.

- (2) Position the Heading Select Pointer in the quadrant toward the Lateral Deviation Needle and select the desired intercept angle by rotating the HDG knob on the HSD.
  - (3) Simultaneously press HDG & APPR buttons on the controller. HDG & APPR buttons will light. Aircraft will turn toward the heading selected until the Lateral Deviation Needle moves approximately one dot away from full deflection. At this time, the HDG button light on controller will go out and the aircraft will assume an automatic 45° intercept angle.
- (b) Fixed Intercept Angle
- (1) Align the Course Arrow to the published inbound course by rotating the CRS knob on the HSD.
  - (2) Press the APPR button on the controller. APPR button light will come on and aircraft will turn left or right depending upon the relation of the aircraft heading to that of the localizer inbound heading. Aircraft will automatically assume an intercept course no more than 45° to the localizer. For the reason explained in Paragraph 1-2b, do not select APPR until the aircraft heading is less than 120° from the localizer inbound heading.
- (2) When the APPR button is pressed, Glide Slope is automatically armed and the aircraft will bracket the Glide Slope and begin a rate of descent commensurate with the Glide Slope angle and airspeed providing the following conditions are met:
    - (a) Glide Slope Pointer on HSD is centered.
    - (b) Pitch command disk is in center detent (altitude hold) position.
    - (c) Aircraft is established on localizer beam at least 20 seconds prior to Glide Slope interception.
    - (d) Auto G.S. disable knob is not pulled.

When the aircraft couples to the Glide Slope signal the GS light on the controller will light.
  - (3) Glide Slope may be disengaged and altitude or attitude maintained while flying the localizer by pulling the auto G.S. Disable knob, or pressing NAV button on the controller or rotating the pitch command disk out of detent until the aircraft has departed the Glide Slope by one dot.
  - (4) For a Back Course Localizer approach select the localizer front course inbound heading. Press REV Button on controller. Both APPR and REV button lights will light indicating to the pilot that he is in both the localizer and reverse modes.
  - (5) Go-around button on the right side of the pilot's control wheel may be pressed anytime the pilot decides not to continue the approach to landing. Pressing the GA button will cause the aircraft to automatically assume a pitch attitude of approximately eight degrees nose up (pilot must adjust power settings to maintain airspeed). Aircraft will continue to hold on to localizer. GA light on controller will light. If a missed approach heading is selected and HDG button pressed, aircraft will turn to selected heading, and remain in a pitch up attitude of approximately 8 degrees. Movement of the pitch command disk will disengage the GA mode. GA light will go out, aircraft will take up a wings-level attitude depending on position of pitch command disk.
  - (6) If the approach is carried to completion, the Automatic Pilot Release Switch must be momentarily pressed prior to landing, thus disconnecting the Automatic Pilot and returning the aircraft to manual control for completion of the landing.

## 3. EMERGENCY OPERATING PROCEDURE

a. In the event a malfunction in the AutoPilot performance is detected, the pilot must immediately disengage the AutoPilot by momentarily pressing the AUTOPILOT RELEASE Switch on the control wheel.

b. Maximum altitude loss during malfunction test in the following flight configuration;

- (1) Cruise, Climb, Descent 160 ft.
- (2) ILS Approach 100 ft.

## 4. PLACARDS

a. On left control wheel:

A/P OFF

b. On left control wheel or throttle quadrant:

G/A

c. On AutoPilot master switch:

ALT V FD/AP OFF

d. On instrument panel:

TRIM                      TRIM  
WARNING                  TEST

FAA APPROVED April 15, 1970  
REVISED: February 23, 1976

REPORT: 1630 PART I PAGE 35  
MODEL: PA-23-250 (Six Place)  
SN 27-4426, 27-4574 and up

AZTEC "E"

---

THIS PAGE INTENTIONALLY LEFT BLANK

REPORT: 1630 PART I PAGE 36  
MODEL: PA-23-250 (Six Place)  
SN 27-4426, 27-4574 and up

FAA APPROVED April 15, 1970

## 8. INSTALLATION OF ALTIMATIC V

## NOTE

The maximum altitude for operation of the AutoPilot has not been determined. The maximum altitude demonstrated during flight tests was 24,000 feet.

## 1. LIMITATIONS

- a. AutoPilot OFF during take-off and landing.
- b. Do not engage AutoPilot if airplane is out of trim.
- c. Maximum airspeed for AutoPilot operation is 240 mph (209 kts) CAS.
- d. During AutoPilot operation, the pilot must be in his seat with the safety belt fastened.
- e. Do not manually override AutoPilot to produce or prevent pitch attitude changes or to increase bank angle.
- f. During AutoPilot operation, the wing flaps must be fully retracted.

## 2. NORMAL OPERATING PROCEDURES

- a. AUTOPILOT MASTER SWITCH - Turn the AutoPilot Master Switch to "ON."
- b. BEFORE TAKE-OFF - Engage the AutoPilot, apply a force to the controls (on one axis at a time) to determine if the AutoPilot may be overpowered.
  - (1) Press HDG, NAV, APPR, REV buttons one at a time, place pitch command disk in center detent position and check respective lights on the Flight Controller for operation.
  - (2) Disengage the AutoPilot and recheck aircraft pitch trim before take-off.
- c. PITCH TRIM INDICATOR - Centering the Pitch Trim Indicator (by rotating the pitch command) prior to engagement will insure that the aircraft will continue in its present attitude. However, if the Trim Indicator is not centered, aircraft will smoothly take up the attitude dictated by the pitch command.
- d. GYRO CHECK - Check Attitude Gyro for proper erection. Set the Directional Gyro, if manual slaving type.
- e. RELEASE SWITCH - The AutoPilot Release Switch is located on the left side of the pilot's control wheel. Momentarily pressing this switch disengages the AutoPilot.
- f. ENGAGE BUTTON - This button is located on the left side of the AutoPilot Controller. Manually adjust aircraft trim prior to engaging AutoPilot. Place aircraft in WINGS-LEVEL attitude. Press the ENGAGE BUTTON which will light upon engagement.
  - (1) To climb, rotate the Pitch Command Disk to UP. To descend, rotate the Pitch Command Disk to DN. The change in pitch ANGLE is determined by the amount of rotation of the pitch command disk.
  - (2) To make turns, use heading mode. See Step j.
- g. AUTOMATIC PITCH TRIM is provided whenever the AutoPilot is engaged. Any attempt to overpower the AutoPilot pitch axis will cause the pitch trim to oppose the applied force, resulting in an out-of-trim condition and high stick forces.  
To manually operate the elevator trim tab, the AutoPilot must be disengaged. Pushing the RELEASE switch will disengage the AutoPilot.
- h. MANUAL ELECTRIC TRIM is provided as standard equipment with the PIPER ALTIMATIC V installation. The following operating instructions apply:

### General

The manual electric trim system is powered through the aircraft Master Switch which must be on for electric trim operation. A circuit breaker located on the circuit breaker panel provides circuit protection. Electric trim is obtained by actuating the Electric Trim Switch on the pilot's control wheel in the desired direction. During normal A/P operations, actuations of the trim switch in either direction disconnects A/P and electric trim is immediately available. A system fault or malfunction will be indicated by the trim warning light, but trim will not run away (see Emergency Procedures).

### Emergency Procedures

In the event of an in-flight malfunction of the electric trim system, disconnect by pulling electric trim circuit breaker.

### Pre-Flight

The following pre-flight shall be conducted prior to each flight and during flight as considered appropriate.

- (1) A/P Master Switch - ON.
- (2) Trim Warning Light - OUT.
- (3) Manual Trim Crank Freedom of Movement - Check.
- (4) Actuate Electric Trim Slide Switch and observe proper direction of movement of manual trim crank - Check.
- (5) Press the press-to-test button next to the trim warning light. Light should light while being pressed and trim should not run - Check.

### i. AUTOMATIC ALTITUDE CONTROLLER

- (1) Altitude control is automatically engaged when the pitch command disk is in the center detent position unless the altitude control disable switch on the front of the flight controller is pulled.
- (2) Rotating the pitch command disk from detent position disengages altitude control and glide slope.
- (3) When pitch command disk is in center detent position, ALT light on flight controller will light.

### NOTE

The altitude controller attempts to maintain the aircraft at the selected altitude by changing the pitch attitude of the aircraft. The human pilot must then maintain power settings to assure a safe airspeed.

j. HEADING SELECTOR - The heading knob on the Directional Gyro may be used to select any heading prior to pushing the (HDG) heading engage button. When the heading engage button is pressed, the aircraft will turn to the selected heading in the direction which is less than  $180^\circ$ , and at a bank angle of no more than  $25^\circ$ , and HDG light on the heading button will light.

k. NAV COUPLING - The pilot may intercept and track a VOR station by the following steps:

- (1) Select the desired OMNI course on the appropriate NAV Indicator O.B.S.
- (2) Position the Heading Bug on the Directional Gyro to the same course as selected on the NAV Indicator.
- (3) Press the NAV button. Button light comes on. Aircraft will turn left or right, depending upon the relation of the aircraft heading to that of the selected OMNI heading. If the OMNI bearing selected is less than  $120^\circ$  from the aircraft heading

when the NAV mode is selected, the aircraft will turn toward the selected OMNI course. At angles of  $120^\circ$  or greater, the aircraft will turn away from the selected OMNI course and continue to turn through the larger angle until a proper intercept course is established. In either case, the aircraft will assume an intercept course which will be no greater than  $45^\circ$  to the selected OMNI course.

## 1. AUTOMATIC APPROACH COUPLER

### NOTE

Coupled approaches must be conducted with wing flaps fully retracted.

- (1) Select proper localizer frequency on appropriate NAV receiver.
- (2) Align Heading Bug on Directional Gyro to published INBOUND course.
- (3) Press the APPR button on the controller. APPR button light will come on and aircraft will turn left or right depending upon the relation of the aircraft heading to that of the localizer inbound heading. Aircraft will automatically assume an intercept course no more than  $45^\circ$  to the localizer. For the reason explained in Paragraph k-3, do not select APPR until the aircraft heading is less than  $120^\circ$  from the localizer inbound heading.
- (4) When the APPR button is pressed, Glide Slope is automatically armed and the aircraft will bracket the Glide Slope and begin a rate of descent commensurate with the Glide Slope angle and airspeed providing the following conditions are met:
  - (a) Glide Slope Pointer on NAV Indicator is centered.
  - (b) Pitch command disk is in center detent (altitude hold) position.
  - (c) Aircraft is established on localizer beam at least 20 seconds prior to Glide Slope interception.
  - (d) Auto G.S. disable knob is not pulled.

When the aircraft couples to the Glide Slope signal the GS light on the controller will light.
- (5) Glide Slope may be disengaged and altitude or attitude maintained while flying the localizer by pulling the Auto G.S. disable knob, or pressing NAV button on the controller or rotating the pitch command disk out of detent until the aircraft has departed the Glide Slope by one dot.
- (6) For a Back Course Localizer approach select the localizer front course inbound heading. Press REV button on controller. Both APPR and REV button lights will light indicating to the pilot that he is in both the localizer and reverse modes.
- (7) Go-around button on the right side of the pilot's control wheel or throttle quadrant may be pressed anytime the pilot decides not to continue the approach to landing. Pressing the GA button will cause the aircraft to automatically assume a pitch attitude of approximately eight degrees nose up (pilot must adjust power settings to maintain airspeed). Aircraft will continue to hold on to localizer. GA light on controller will light. If a missed approach heading is selected and HDG button pressed, aircraft will turn to selected heading, and remain in a pitch up attitude of approximately eight degrees. Movement of the pitch command disk will disengage the GA mode. GA light will go out, aircraft will take up a wings-level attitude depending on the position of pitch command disk.
- (8) If the approach is carried to completion, upon reaching ILS minimums the Automatic Pilot Disengage Switch must be momentarily pressed, thus disconnecting the Automatic Pilot and returning the aircraft to manual control for completion of the landing.



3. EMERGENCY OPERATING PROCEDURE.

a. In the event a malfunction in the AutoPilot performance is detected, the pilot must immediately disengage the AutoPilot by momentarily pressing the AUTOPILOT RELEASE Switch on the control wheel.

b. Maximum altitude loss during malfunction test in the following flight configuration;

(1) Cruise, Climb, Descent 160 ft.

(2) ILS Approach 100 ft.

4. PLACARDS

a. On left control wheel:

A/P          OFF

b. On left control wheel or throttle quadrant:

G/A

c. On AutoPilot master switch:

ALT V A/P          OFF

d. On instrument panel:

TRIM                  TRIM  
WARNING              TEST

## 9. PIPER ALTIMATIC IIIB-1 (Includes Roll, Pitch, AutoFlite II and Pitch Trim Sections.)

## 1. LIMITATIONS

- a. The maximum speed for Autopilot operation is 215 MPH CAS.
- b. Use of flaps not authorized during Autopilot operation.
- c. Autopilot OFF for take-off and landing.
- d. Reduce Autopilot maximum operating speed 5 MPH per each 1000 ft. above 21,000 ft. on aircraft equipped with turbochargers.

## 2. PROCEDURES

## a. PREFLIGHT

## (1) Roll Section

With heading lock button "OUT" (off) and radio coupler in "Heading" mode, engage roll section. Rotate roll knob full right and full left. Determine that the control wheel describes a corresponding right and left turn, then center knob. Check to see that the servo can be overridden by hand at the control wheel. Disengage prior to take-off.

## (2) Pitch Section

With altitude preselect button "OUT" and "ROLL" and "PITCH" button pushed in, rotate the pitch command disc full DOWN and full UP. Determine that the control wheel describes a corresponding fore and aft movement. Check to see that the servo can be overridden by hand at the control wheel. Center the disc and disengage prior to take-off.

## (3) Command/Automatic Pitch Trim (General)

This aircraft is equipped with a Trim System designed to withstand any type of single malfunction, either mechanical or electrical, without uncontrolled operation resulting. The preflight check procedure is designed to uncover hidden failures that might otherwise go undetected. If the Trim System fails any portion of the following test procedure, pull the trim circuit breaker and recheck for operation. If trim does not operate with circuit breaker out, leave circuit breaker out until trim system is repaired. If trim operation results with trim circuit breaker OUT, the circuit breaker has failed or some other malfunction exists. Correct this or have an Autopilot Specialist disconnect trim servo plug at the servo prior to flight. Substitution of any trim system component from another model is not authorized.

The Command Electric Trim Switch on the left hand portion of the pilot's control wheel has two functions:

- (a) When the top bar is pressed (AP off), it disconnects the Autopilot or interrupts the Stabilizer Back-up system.
- (b) When the top bar is pressed and the rocker is moved forward, nose down trim will occur - when moved aft, nose up trim will occur.

## TEST PROCEDURE

- (a) Check trim circuit breaker - IN.
- (b) AP OFF - check normal trim operation - UP and DN.
- (c) Press center bar only - trim should not operate.
- (d) Without pressing center bar, move rocker fore and aft - Trim should not operate.
- (e) AP ON - (Roll and Pitch Sections) Check automatic operation by activating AP Pitch Command Disc UP, then DN. Observe trim operation follows Pitch Command Direction.

## NOTE

1. In Autopilot Mode, there will be approximately a 3 second delay between operation of Pitch Command and operation of Trim.
2. During ground check, additional control wheel pressure might be necessary to cause trim operation, due to low Autopilot authority during ground operation.

(f) Press center bar (AP off) - release - check AP disengagement.

(g) Rotate trim crank to check manual trim operation.

## CAUTION

Recheck aircraft pitch trim to correct take-off position after Autopilot and Trim System check.

## b. AUTOFLITE II SECTION (Normal Operation)

The AutoFlite II section of the AltiMatic IIIB-1 may be used full time except for take-off and landing.

## (1) Engagement

(a) Rocker Switch on instrument panel - ON.

(b) Interrupt Switch on left hand side of pilot's control wheel - RELEASED.

## (2) Disengagement

(a) Grip Interrupt Switch on pilot's control wheel (or)

(b) Rocker Switch on instrument panel - OFF.

## (3) Heading Changes

(a) Grip Interrupt Switch, make Heading Change, release Interrupt Switch.

(b) Move Trim Knob on instrument for Drift Correction from a Constant Heading.

(c) Move Turn Command Knob on instrument for right or left banked turns.

## c. IN-FLIGHT

(1) Trim airplane (ball centered).

(2) Check vacuum and ascertain that the directional gyro and artificial horizon are functioning properly.

(3) Roll Section

To engage, push console heading lock button (HDG) "OUT". Center ROLL knob. Push ROLL button to "ON" (in) position. To turn rotate console ROLL knob in desired direction. (Maximum angle of bank should not exceed 30°.) For heading lock, set directional gyro with magnetic compass. Push directional gyro HDG knob in, rotate to select desired heading. Push console heading lock button (HDG) to "ON" position. (Maximum angle of bank will be 20° with heading lock engaged.)

(4) Pitch Section - Roll Section must be engaged prior to engaging Pitch Section.

To engage, push Altitude Preselect Button (ALT) to "OFF" position. Center pitch trim indicator with the pitch command disc. Push PITCH button to "ON" position. To change altitude, rotate PITCH command disc in desired direction.

To preselect altitude, center PITCH command disc. With airplane in level flight, rotate the altitude selector knob until pitch trim indicator is level. Calibrate the altitude indicator to match altimeter by rotating the knurled altitude indicator dial. Rotate the altitude selector knob to select desired altitude. Push altitude preselect button (ALT) to "ON" position. The altitude preselect button may also be engaged when the aircraft is climbing or descending. Rotate the altitude selector knob until trim indicator indicates UP or DOWN as desired, then engage the altitude preselect button. The selected altitude will be held. With the pitch command disc centered, the altitude selector mode is preset to provide approximately a 7° climb attitude or a 4° descent attitude. If a higher or lower climb rate or attitude is desired, the pitch command disc can be used, in the normal manner, to adjust attitude. Once the selected altitude has been reached the pitch command disc will become inoperative until another altitude is selected or the altitude selector mode is disengaged.

(5) VOR Navigation

(a) To Intercept

Using OMNI Bearing Selector, dial desired course, inbound or outbound.

Set identical heading on Course Selector D. G.

After aircraft has stabilized, position coupler mode selector knob to OMNI mode.

NOTE

If aircraft position is less than 45° from selected radial, aircraft will intercept before station; if more than 45°, interception will occur after station passage.

As aircraft nears selected radial, interception and crosswind correction will be automatically accomplished without further switching.

As the aircraft nears the OMNI station, (1/2 mile) the zone of confusion will direct an "S" turn in alternate directions as the OMNI indicator needle swings. This alternate banking limited to the standard D. G. bank angle, is an indication of station passage.

(b) To Select New Course

To select any different outbound course or radial, including reciprocal of the previous inbound radial, dial the new course into the Course Selector D.G.

Rotate OBS to the new course.

Aircraft will automatically turn, in the shortest direction to the interception heading for the new course.

(c) To Change Stations

If same course is desired, merely tune receiver to new station frequency.

If different course is desired, position coupler mode selector to HDG mode.

Dial Course Selector D. G. to new course.

Dial OBS to new course.

Position mode selector to OMNI mode.

## (6) VOR Approach

Track inbound to station as described in VOR Navigation section. After station passage (when "S" turn starts) dial outbound course on Course Selector D.G. then dial same course on OBS.

After established on outbound radial, position mode selector to HDG mode and select outbound procedure turn heading. After one minute, dial inbound procedure turn heading on Course Selector D. G. dialing toward desired turn. Set OBS to inbound course.

When headed 90° to inbound course, dial Course Selector D. G. to inbound course and position mode selector to OMNI mode.

Use altitude selector mode to maintain altitude inbound to VOR from procedure turn, if called for in approach procedure.

At VOR station, mark time and select minimum descent altitude (MDA) on altitude selector. When aircraft begins descent, lower landing gear, adjust power and adjust correct (desired) descent angle by adjusting pitch command disc. The altitude selector will cause aircraft to level off at the selected MDA. Maintain cross check of airspeed, altitude, course and elapsed time throughout the approach. At the correct elapsed time, either:

- (a) Disengage Autopilot and prepare for landing, or
- (b) Execute a missed approach (See Missed Approach Section c. (10).

If holding pattern is desired, position mode selector on HDG mode at station passage inbound and select outbound heading in direction of turn.

After elapsed time, dial inbound course on Course Selector D. G. When headed 90° to radial, position mode selector to OMNI mode.

## NOTE

For precise tracking over OMNI Station, without "S" turn, position mode selector on HDG until station passage.

## (7) LOC Approach Only.

- (a) To Intercept

Dial ILS outbound course on Course Selector D. G. When stabilized, position mode selector to LOC REV mode.

- (b) After interception and when beyond outer marker, position mode selector to HDG and dial outbound procedure turn heading. After one minute, dial inbound procedure turn heading in direction of turn.

When 90° to ILS inbound course, dial inbound course on Course Selector D. G. and position mode selector to LOC NORM mode. Use pitch modes in the same manner as described in c. (6) for VOR approach. When beyond midpoint of runway, or when missed approach is elected, position mode selector to HDG mode and execute missed approach procedure.

## (8) LOC Approach - Back Course

- (a) To Intercept

Dial ILS Back Course outbound heading on Course Selector D. G. When stabilized, position mode selector to LOC NORM mode.

- (b) After interception and when beyond fix, position mode selector to HDG and dial outbound procedure turn heading. After one minute, dial inbound procedure turn heading in direction of turn.

When headed 90° to inbound course, dial inbound course on Course Selector D.G. and position mode selector on LOC REV mode.

Use pitch modes in the same manner as described in c. (6) for VOR approach. Approximately 1/2 mile from runway, position mode selector to HDG mode to prevent "S" turn over ILS station near runway threshold.

(9) Automatic ILS and Glide Slope Coupler

(a) The optional Glide Slope Coupler installation incorporates a logic circuit which will automatically activate Glide Slope Coupling under the following conditions.

1. Coupler in LOC NORM mode.
2. Altitude Selector.
3. Glide Slope Indicator needle UP more than 60 percent of scale for 20 seconds.
4. Glide Slope Indicator needle reaches center after fulfilling condition 3. A green panel light labeled G/S when on, indicates coupling has occurred.

Note that these conditions are designed into the logic circuit so that normal approach procedures will give automatic glide slope coupling.

(b) To deactivate the Glide Slope Coupler, any one of the following steps may be taken.

1. Switch altitude selector OFF. NOTE: Momentary off is sufficient to deactivate.
2. Switch radio coupler to HDG mode.
3. Disconnect Autopilot.

NOTE

Do not select LOC NORM mode prior to 90 degrees as glide slope antenna blanking may cause premature activation of glide slope coupling.

- (c) Approach Glide Path (outer marker) with gear up at approximately 140 MPH.
- (d) Upon intercept of Glide Path, aircraft will assume slight nose down attitude and Glide Slope light will come on.
- (e) Immediately lower landing gear at Glide Slope Intercept. Adjust power to maintain 120 to 140 MPH.
- (f) Upon completion of Glide Slope Coupler approach, or when VFR, disconnect Autopilot and adjust aircraft for landing configuration.
- (g) For missed approach procedure, both engines operating, switch Coupler to HDG mode and put in climb power, raise gear and set Autopilot to missed approach altitude and HDG.
- (h) Single Engine operation, same as (9) (c) through (f).

(10) Missed Approach Procedure

At the decision to miss the approach (Go Around) execute the following procedure:

- (a) Select HDG mode on Radio Coupler - This breaks the Glide Slope Coupler Circuit causing the Autopilot to return to Altitude Selector mode. Adjust Altitude Selector and Pitch Command Disc as required to assure climb attitude.
- (b) Immediately add climb power, and
- (c) raise landing gear
- (d) select missed approach HDG with HDG indice.

d. EMERGENCY OPERATION

- (1) In the event of malfunction, the Autopilot can be:
  - (a) Disconnected by pushing the wheel disconnect switch.
  - (b) Disconnected by pushing the Roll rocker switch "OFF".
  - (c) Disconnected by pulling the Autopilot circuit breaker.
  - (d) Overpowered manually in Roll and Pitch at either control wheel.
- (2) The Trim System can be:
  - (a) Disabled electrically by pulling the Trim Circuit Breaker.
  - (b) Overpowered manually at the Trim crank.
- (3) Single Engine Operation - Roll and Pitch Modes:
  - (a) Disengage Autopilot and retrim aircraft. Maintain aircraft in trim throughout all Single Engine operations. (Ball centered).
  - (b) Perform normal engine out emergency procedure.
  - (c) Re-engage Autopilot.
- (4) Single Engine Operation - HDG or Coupled
  - (a) Retrim aircraft. Maintain aircraft in trim throughout all Single Engine operations. (Ball centered).
  - (b) Perform normal engine out procedure.
- (5) Altitude loss - Cruise 3 second delay in recovery could result in a 60° bank and a 420 foot altitude loss.
- (6) Altitude loss - high altitude descent - 3 second delay in recovery could result in a 35° bank and a 600 foot altitude loss.
- (7) Altitude loss - Approach - multi-engine or single engine - coupled or uncoupled - 1 second delay in recovery could result in a 20° bank and a 100 foot altitude loss.
- (8) The AutoFlite II (In case of malfunction):
  - (a) GRIP Interrupt Switch on pilot's control wheel.
  - (b) Rocker Switch on instrument panel - OFF.
  - (c) Reset Circuit Breaker to restore Turn and Bank Operation.
  - (d) Unit may be overpowered manually.
  - (e) In cruise configuration malfunction, 3 second delay results 60° bank and 300 foot altitude loss.
  - (f) In approach configuration, single engine or multi-engine, coupled or uncoupled, a malfunction, with a 1 second delay in recovery could result in a 20° bank and 60 foot altitude loss.
  - (g) In case of engine failure, disengage AutoFlite II, retrim aircraft, perform normal engine out procedures and re-engage AutoFlite II.

3. PERFORMANCE: No change

## 10. INSTALLATION OF ALTIMATIC V F/D-1

## NOTE

The maximum altitude for operation of the AutoPilot has not been determined. The maximum altitude demonstrated during flight tests was 24,000 feet.

## 1. LIMITATIONS

- a. AutoPilot OFF during takeoff and landing.
- b. Do not engage AutoPilot if airplane is out of trim.
- c. Maximum airspeed for AutoPilot operation is 240 mph (209 kts) CAS.
- d. During Flight Director/AutoPilot operation, the pilot must be in his seat with the safety belt fastened.
- e. Do not manually override AutoPilot to produce or prevent pitch attitude changes or to increase bank angle.
- f. During AutoPilot operation, the wing flaps must be fully retracted.

## 2. NORMAL OPERATING PROCEDURES

- a. FD/AP MASTER SWITCH - Turn the FD/AP Master Switch to ON.
- b. The Flight Director incorporates a Director Horizon in lieu of the conventional Artificial Horizon. In addition to supplying attitude information to the computer, the Director Horizon displays command dots which receive information from the computer in the same manner as the AutoPilot servos. By maneuvering the aircraft to satisfy the command dots, the pilot is acting in the same manner as the AutoPilot servos.
- c. Adjust pitch command to align the command dots with the simulated red tip tanks of the Director Horizon.
- d. BEFORE TAKEOFF - Engage the AutoPilot, apply a force to the controls (on one axis at a time) to determine if the AutoPilot may be overpowered.
  - (1) Press HDG, NAV, APPR, REV buttons one at a time, place pitch command disc in center detent position and check respective lights on the Flight Controller for operation.
  - (2) Disengage the AutoPilot and recheck aircraft pitch trim before takeoff.
- e. PITCH TRIM INDICATOR - Centering the Pitch Trim Indicator (by rotating the pitch command) prior to engagement will insure that the aircraft will continue in its present attitude. However, if the Trim Indicator is not centered, aircraft will smoothly take up the attitude dictated by the pitch command.
- f. RELEASE SWITCH - The AutoPilot Release Switch is located on the left side of the pilot's control wheel. Momentarily pressing this switch disengages the AutoPilot.
- g. ENGAGE BUTTON - This button is located on the left side of the AutoPilot Controller. Manually adjust aircraft trim prior to engaging AutoPilot. Place aircraft in WINGS-LEVEL attitude. Press the ENGAGE BUTTON which will light upon engagement.
  - (1) To climb, rotate the Pitch Command Disc to UP. To descend, rotate the Pitch Command Disc to DN. The change in pitch ANGLE is determined by the amount of rotation of the pitch command disc.
  - (2) To make turns, use heading mode. See Step k.



h. AUTOMATIC PITCH TRIM is provided whenever the AutoPilot is engaged. Any attempt to overpower the AutoPilot pitch axis will cause the pitch trim to oppose the applied force, resulting in an out-of-trim condition and high stick forces.

To manually operate the elevator trim tab, the AutoPilot must be disengaged. Pushing the RELEASE switch will disengage the AutoPilot.

i. MANUAL ELECTRIC TRIM is provided as standard equipment with the PIPER ALTIMATIC V F/D-1 installation. The following operating instructions apply:

#### General

The manual electric trim system is powered through the aircraft Master Switch which must be on for electric trim operation. A circuit breaker located on the circuit breaker panel provides circuit protection. Electric trim is obtained by actuating the Electric Trim Switch on the pilot's control wheel in the desired direction. During normal A/P operations, actuations of the trim switch in either direction disconnects A/P and electric trim is immediately available. A system fault or malfunction will be indicated by the trim warning light, but trim will not run away (see emergency procedures).

#### Emergency Procedures

In the event of an in-flight malfunction of the electric trim system, disconnect by pulling electric trim circuit breaker.

#### Preflight

The following preflight shall be conducted prior to each flight and during flight as considered appropriate.

- (1) FD/AP Master Switch - ON
- (2) Trim Warning Light - OUT
- (3) Manual Trim Crank Freedom of Movement - Check
- (4) Actuate Electric Trim Slide Switch and observe proper direction of movement of manual trim crank - Check
- (5) Press the press-to-test button next to the trim warning light. Light should light while being pressed and trim should not run - Check.

j. AUTOMATIC ALTITUDE CONTROLLER

- (1) Altitude control is automatically engaged when the pitch command disc is in the center detent position unless the altitude control disable switch on the front of the flight controller is pulled.
- (2) Rotating the pitch command disc from detent position disengages altitude control and glide slope.
- (3) When pitch command disc is in center detent position, ALT light on flight controller will light.

#### NOTE

The altitude controller attempts to maintain the aircraft at the selected altitude by changing the pitch attitude of the aircraft. The human pilot must then maintain power settings to assure a safe airspeed.

k. **HEADING SELECTOR** - The heading knob on the Horizontal Situation Display may be used to select any heading prior to pushing the (HDG) heading engage button. When the heading engage button is pressed, the command dots will command the direction and attitude to satisfy the heading command, the aircraft will turn to the selected heading in the direction which is less than  $180^\circ$ , and at a bank angle of no more than  $25^\circ$ , and HDG light on the heading button will light.

l. **OMNI BEARING SELECTOR** - There are two methods of intercepting a VOR.

(1) **Variable Intercept Angle** - With this method, the pilot may preselect any intercept angle desired.

(a) After identifying desired OMNI station, select desired OMNI course on the Horizontal Situation Display by rotating the CRS knob on the HSD until the course arrow aligns with the desired OMNI course.

(b) Position the Heading Select Pointer (heading bug) in the quadrant toward the Lateral Deviation Needle (left/right needle) and select the desired intercept angle by rotating the HDG knob on the Horizontal Situation Display. The number of degrees between the Course Arrow and the Heading Select Pointer is the intercept angle. For obvious reasons the pilot should not select an intercept angle less than  $20^\circ$  or more than  $90^\circ$ .

(c) Simultaneously press HDG and NAV buttons on the controller. HDG and NAV buttons will light. Aircraft will turn toward the heading selected until the Lateral Deviation Needle moves approximately one dot away from full deflection. At this time, the HDG button light on the controller will go out and the aircraft will assume an automatic  $45^\circ$  intercept angle.

(2) **Fixed Intercept Angle**

(a) After identifying the desired OMNI station, select desired OMNI course on the Horizontal Situation Display by rotating the CRS knob on the HSD until the course arrow aligns with the desired OMNI course.

(b) Press the NAV button. Button light comes on. Aircraft will turn left or right, depending upon the relation of the aircraft heading to that of the selected OMNI heading. If the OMNI bearing selected is less than  $120^\circ$  from the aircraft heading when the NAV mode is selected, the aircraft will turn toward the selected OMNI course. At angles of  $120^\circ$  or greater, the aircraft will turn away from the selected OMNI course and continue to turn through the larger angle until a proper intercept course is established. In either case, the aircraft will assume an intercept course which will be no greater than  $45^\circ$  to the selected OMNI course.

m. **AUTOMATIC APPROACH COUPLER**

#### NOTE

Coupled approaches must be conducted with the wing flaps fully retracted.

(1) As in the case of the NAV mode, there are two methods of intercepting the localizer.

(a) **Variable Intercept Angle** - This method is very handy when being vectored toward the localizer, by approach control, with the Headings and APPR modes engaged.

(1) **Align Course Arrow** to the published inbound course by rotating the CRS knob on the HSD.

- (2) Position the Heading Select Pointer in the quadrant toward the Lateral Deviation Needle and select the desired intercept angle by rotating the HDG knob on the HSD.
  - (3) Simultaneously press HDG & APPR buttons on the controller. HDG & APPR buttons will light. Aircraft will turn toward the heading selected until the Lateral Deviation Needle moves approximately one dot away from full deflection. At this time, the HDG button light on controller will go out and the aircraft will assume an automatic 45° intercept angle.
- (b) Fixed Intercept Angle
- (1) Align the Course Arrow to the published inbound course by rotating the CRS knob on the HSD.
  - (2) Press the APPR button on the controller. APPR button light will come on and the aircraft will turn left or right depending upon the relation of the aircraft heading to that of the localizer inbound heading. Aircraft will automatically assume an intercept course no more than 45° to the localizer. For the reason explained in Paragraph 1-2b, do not select APPR until the aircraft heading is less than 120° from the localizer inbound heading.
- (2) When the APPR button is pressed, Glide Slope is automatically armed and the aircraft will bracket the Glide Slope and begin a rate of descent commensurate with the Glide Slope angle and airspeed providing the following conditions are met:
- (a) Glide Slope Pointer on HSD is centered.
  - (b) Pitch command disc is in center detent (altitude hold) position.
  - (c) Aircraft is established on localizer beam at least 20 seconds prior to Glide Slope interception.
  - (d) GS disable knob is not pulled. >

## NOTE

This system is equipped with a manual Glide Slope button and can capture the Glide Slope automatically as outlined in Paragraph m.

(2), or manually by pressing the GS button when the Glide Slope Pointer centers, providing the aircraft is in altitude hold and APPR mode, and GS disable knob is not pulled.

- (3) When the aircraft couples to the Glide Slope signal the GS light on the controller will light and ALT light extinguishes.
- (4) Glide Slope may be disengaged and altitude or attitude maintained while flying the localizer by pulling the GS Disable knob, or pressing NAV button on the controller or rotating the pitch command disc out of detent until the aircraft has departed the Glide Slope by one dot.
- (5) For a Back Course Localizer approach select the localizer front course inbound heading. Press REV button on controller. Both APPR and REV button lights will light indicating to the pilot that he is in both the localizer and reverse modes.
- (6) Go-around button in the left throttle lever knob may be pressed anytime the pilot decides not to continue the approach to landing. Pressing the GA button will cause the aircraft to automatically assume a pitch attitude of approximately eight degrees nose up (pilot must adjust power settings to maintain airspeed). Aircraft

will continue to hold on to localizer. GA light on controller will light. If a missed approach heading is selected and HDG button pressed, aircraft will turn to selected heading, and remain in a pitch up attitude of approximately 8 degrees. Movement of the pitch command disc will disengage the GA mode. GA light will go out, aircraft will take up a wings-level attitude depending on position of pitch command disc.

- (7) If the approach is carried to completion, the Automatic Pilot Release Switch must be momentarily pressed prior to landing, thus disconnecting the Automatic Pilot and returning the aircraft to manual control for completion of the landing.

### 3. EMERGENCY OPERATING PROCEDURE

a. In the event a malfunction in the AutoPilot performance is detected, the pilot must immediately disengage the AutoPilot by momentarily pressing the AUTOPILOT RELEASE Switch on the control wheel.

b. Maximum altitude loss during malfunction test in the following flight configurations:

- (1) Cruise, Climb, Descent 160 ft.
- (2) ILS Approach 100 ft.

### 4. PLACARDS

a. On left control wheel:

A/P OFF

b. On left throttle quadrant:

G/A

c. On AutoPilot master switch:

ALT V FD/AP OFF

d. On instrument panel:

TRIM	TRIM
WARNING	TEST

AZTEC "E"

---

THIS PAGE INTENTIONALLY LEFT BLANK.

REPORT: 1630 PART I PAGE 52  
MODEL: PA-23-250 (Six Place)  
SN 27-4426, 27-4574 and up

FAA APPROVED November 7, 1972

## 11. INSTALLATION OF ALTIMATIC V-1

## NOTE

The maximum altitude for operation of the AutoPilot has not been determined. The maximum altitude demonstrated during flight tests was 24,000 feet.

## 1. LIMITATIONS

- a. AutoPilot OFF during takeoff and landing.
- b. Do not engage AutoPilot if airplane is out of trim.
- c. Maximum airspeed for AutoPilot operation is 240 mph (209 kts) CAS.
- d. During AutoPilot operation, the pilot must be in his seat with the safety belt fastened.
- e. Do not manually override AutoPilot to produce or prevent pitch attitude changes or to increase bank angle.
- f. During AutoPilot operation, the wing flaps must be fully retracted.

## 2. NORMAL OPERATING PROCEDURES

- a. AUTOPILOT MASTER SWITCH - Turn the AutoPilot Master Switch to ON.
- b. BEFORE TAKEOFF - Engage the AutoPilot, apply a force to the controls (on one axis at a time) to determine if the AutoPilot may be overpowered.
  - (1) Press HDG, NAV, APPR, REV buttons one at a time, place pitch command disc in center detent position and check respective lights on the Flight Controller for operation.
  - (2) Disengage the AutoPilot and recheck aircraft pitch trim before takeoff.
- c. PITCH TRIM INDICATOR - Centering the Pitch Trim Indicator (by rotating the pitch command) prior to engagement will insure that the aircraft will continue in its present attitude. However, if the Trim Indicator is not centered, aircraft will smoothly take up the attitude dictated by the pitch command.
- d. GYRO CHECK - Check Attitude Gyro for proper erection. Set the Directional Gyro, if manual slaving type.
- e. RELEASE SWITCH - The AutoPilot Release Switch is located on the left side of the pilot's control wheel. Momentarily pressing this switch disengages the AutoPilot.
- f. ENGAGE BUTTON - This button is located on the left side of the AutoPilot Controller. Manually adjust aircraft trim prior to engaging AutoPilot. Place aircraft in WINGS-LEVEL attitude. Press the ENGAGE BUTTON which will light upon engagement.
  - (1) To climb, rotate the Pitch Command Disc to UP. To descend, rotate the Pitch Command Disc to DN. The change in pitch ANGLE is determined by the amount of rotation of the pitch command disc.
  - (2) To make turns, use heading mode. See Step j.
- g. AUTOMATIC PITCH TRIM is provided whenever the AutoPilot is engaged. Any attempt to overpower the AutoPilot pitch axis will cause the pitch trim to oppose the applied force, resulting in an out-of-trim condition and high stick forces.  
To manually operate the elevator trim tab, the AutoPilot must be disengaged. Pushing the RELEASE switch will disengage the AutoPilot.
- h. MANUAL ELECTRIC TRIM is provided as standard equipment with the PIPER ALTIMATIC V-1 installation. The following operating instructions apply:

FAA APPROVED November 7, 1972

REPORT: 1630 PART I PAGE 53  
 MODEL: PA-23-250 (Six Place)  
 SN 27-4426, 27-4574 and up

### General

The manual electric trim system is powered through the aircraft Master Switch which must be on for electric trim operation. A circuit breaker located on the circuit breaker panel provides circuit protection. Electric trim is obtained by actuating the Electric Trim Switch on the pilot's control wheel in the desired direction. During normal A/P operations, actuations of the trim switch in either direction disconnects A/P and electric trim is immediately available. A system fault or malfunction will be indicated by the trim warning light, but trim will not run away (see Emergency Procedures).

### Emergency Procedures

In the event of an in-flight malfunction of the electric trim system, disconnect by pulling electric trim circuit breaker.

### Preflight

The following preflight shall be conducted prior to each flight and during flight as considered appropriate.

- (1) A/P Master Switch - ON
- (2) Trim Warning Light - OUT
- (3) Manual Trim Crank Freedom of Movement - Check
- (4) Actuate Electric Trim Slide Switch and observe proper direction of movement of manual trim crank - Check
- (5) Press the press-to-test button next to the trim warning light. Light should light while being pressed and trim should not run - Check.

#### i. AUTOMATIC ALTITUDE CONTROLLER

- (1) Altitude control is automatically engaged when the pitch command disc is in the center detent position unless the altitude control disable switch on the front of the flight controller is pulled.
- (2) Rotating the pitch command disc from detent position disengages altitude control and glide slope.
- (3) When pitch command disc is in center detent position, ALT light on flight controller will light.

#### NOTE

The altitude controller attempts to maintain the aircraft at the selected altitude by changing the pitch attitude of the aircraft. The human pilot must then maintain power settings to assure a safe airspeed.

j. **HEADING SELECTOR** - The heading knob on the Directional Gyro may be used to select any heading prior to pushing the (HDG) heading engage button. When the heading engage button is pressed, the aircraft will turn to the selected heading in the direction which is less than 180°, and at a bank angle of no more than 25°, and HDG light on the heading button will light.

k. **NAV COUPLING** - The pilot may intercept and track a VOR station by the following steps:

- (1) Select the desired OMNI course on the appropriate NAV indicator O.B.S.
- (2) Position the Heading Bug on the Directional Gyro to the same course as selected on the NAV Indicator.
- (3) Press the NAV button. Button light comes on. Aircraft will turn left or right, depending upon the relation of the aircraft heading to that of the selected OMNI heading. If the OMNI bearing selected is less than 120° from the aircraft heading

when the NAV mode is selected, the aircraft will turn toward the selected OMNI course. At angles of  $120^\circ$  or greater, the aircraft will turn away from the selected OMNI course and continue to turn through the larger angle until a proper intercept course is established. In either case, the aircraft will assume an intercept course which will be no greater than  $45^\circ$  to the selected OMNI course.

#### 1. AUTOMATIC APPROACH COUPLER

##### NOTE

Coupled approaches must be conducted with wing flaps fully retracted.

- (1) Select proper localizer frequency on appropriate NAV receiver.
- (2) Align Heading Bug on Directional Gyro to published INBOUND course.
- (3) Press the APPR button on the controller. APPR button light will come on and aircraft will turn left or right depending upon the relation of the aircraft heading to that of the localizer inbound heading. Aircraft will automatically assume an intercept course no more than  $45^\circ$  to the localizer. For the reason explained in Paragraph k. (3), do not select APPR until the aircraft heading is less than  $120^\circ$  from the localizer inbound heading.
- (4) When the APPR button is pressed, Glide Slope is automatically armed and the aircraft will bracket the Glide Slope and begin a rate of descent commensurate with the Glide Slope angle and airspeed providing the following conditions are met:
  - (a) Glide Slope Pointer on NAV Indicator is centered.
  - (b) Pitch command disc is in center detent (altitude hold) position.
  - (c) Aircraft is established on localizer beam at least 20 seconds prior to Glide Slope interception.
  - (d) GS disable knob is not pulled.

##### NOTE

This system is equipped with a manual Glide Slope button and can capture the Glide Slope automatically as outlined in Paragraph l. (4) or manually by pressing the GS button when the Glide Slope Pointer centers, provided the aircraft is in altitude hold and APPR mode, and GS disable knob is not pulled.

- (5) When the aircraft couples to the Glide Slope signal the GS light on the controller will light, and ALT light extinguishes.
- (6) Glide Slope may be disengaged and altitude or attitude maintained while flying the localizer by pulling the GS disable knob, or pressing NAV button on the controller or rotating the pitch command disc out of detent until the aircraft has departed the Glide Slope by one dot.
- (7) For a Back Course Localizer approach select the localizer front course inbound heading. Press REV button on controller. Both APPR and REV button lights will light indicating to the pilot that he is in both the localizer and reverse modes.
- (8) Go-around button in the left throttle lever knob may be pressed anytime the pilot decides not to continue the approach to landing. Pressing the GA button will cause the aircraft to automatically assume a pitch attitude of approximately eight degrees nose up (pilot must adjust power settings to maintain airspeed). Aircraft



will continue to hold on to localizer. GA light on controller will light. If a missed approach heading is selected and HDG button pressed, aircraft will turn to selected heading, and remain in a pitch up attitude of approximately eight degrees. Movement of the pitch command disc will disengage the GA mode. GA light will go out, aircraft will take up a wings-level attitude depending on the position of pitch command disc.

- (9) If the approach is carried to completion, upon reaching ILS minimums the Automatic Pilot Disengage Switch must be momentarily pressed, thus disconnecting the Automatic Pilot and returning the aircraft to manual control for completion of the landing.

3. EMERGENCY OPERATING PROCEDURE

a. In the event a malfunction in the AutoPilot performance is detected, the pilot must immediately disengage the AutoPilot by momentarily pressing the AUTOPILOT RELEASE Switch on the control wheel.

b. Maximum altitude loss during malfunction test in the following flight configurations:

- (1) Cruise, Climb, Descent 160 ft.
- (2) ILS Approach 100 ft.

4. PLACARDS

a. On left control wheel:

A/P OFF

b. On left throttle quadrant:

G/A

c. On AutoPilot master switch:

ALT V A/P OFF

d. On instrument panel:

TRIM                      TRIM  
WARNING                 TEST

## 12. INSTALLATION OF PIPER AUTOCONTROL IIIB

## 1. LIMITATIONS

## NOTE

The information contained herein supplements the information of the basic Airplane Flight Manual. For limitations, procedures and performance information not contained in this supplement consult the basic Airplane Flight Manual.

- a. Autopilot use prohibited above 215 MPH CAS. (Autopilot Vmo)
- b. Reduce Autopilot Vmo 5 MPH CAS for each 1000 ft. above 21,000 ft.
- c. Autopilot "OFF" during takeoff and landing.
- d. Use of Flaps Not Authorized during Autopilot Operation.

## 2. PROCEDURES

## a. PREFLIGHT

## Autopilot

- (1) Place Radio Coupler in "Heading" mode (if installed) and place A/P ON/OFF switch in the "ON" position to engage roll section. Rotate roll command knob left and right and observe that control wheel describes a corresponding left and right turn, then center knob.
- (2) Set proper D.G. Heading on D.G. and turn Heading Bug to aircraft heading. Engage "Heading" mode switch and rotate Heading Bug right and left. Aircraft control wheel should turn same direction as Bug. Grasp control wheel as manually override servo, both directions.

## Radio Coupler - (Optional)

- (1) Tune and identify VOR or VOT station. Position Radio Coupler to OMNI Mode. Place A/P ON/OFF and HDG mode rocker switches to the "ON" position. Set Heading Bug to aircraft heading and rotate O.B.S. to cause OMNI Indicator Needle to swing left and right slowly. Observe that control wheel rotates in direction of needle movement.
- (2) Disengage by placing A/P ON/OFF switch to the "OFF" position. Reset Radio Coupler to HDG mode.

## b. IN-FLIGHT

- (1) Trim airplane (ball centered).
- (2) Check air pressure or vacuum to ascertain that the Directional Gyro and Attitude Gyro are receiving sufficient air.
- (3) Roll Section
  - (a) To engage, center Roll Command Knob, place the A/P ON/OFF switch to the "ON" position. To turn rotate Roll Command Knob in desired direction. (Maximum angle of bank should not exceed 30°.)
  - (b) For heading mode, set Directional Gyro with Magnetic Compass. Push directional gyro HDG knob in, rotate Bug to aircraft heading. Place the console HDG ON/OFF switch to the "ON" position. To select a new aircraft heading, push D.G. heading knob "IN" and rotate, in desired direction of turn, to the desired heading.

(4) Radio Coupling VOR/ILS with H.S.I. (Horizontal Situation Indicator) Type Instrument Display - (Optional)

VOR Navigation

- (a) Tune and identify VOR Station. Select desired course by rotating CRS knob of H.S.I.
- (b) Select OMNI mode on Radio Coupler.
- (c) Engage HDG mode on autopilot console to engage coupler. Aircraft will turn to a 45° intercept angle to intercept the selected VOR course. Intercept angle magnitude depends on radio needle off course magnitude, 100% needle deflection will result in 45° intercept with the intercept angle diminishing as the needle off set diminishes.
- (d) NAV mode - NAV mode provides reduced VOR sensitivity for tracking weak, or noisy, VOR signals. NAV mode should be selected after the aircraft is established on course.

ILS/LOC Front Course

- (a) Set inbound, front, localizer course on H.S.I.
- (b) Select LOC/NORM mode on Radio Coupler to intercept and track inbound on the localizer. Select LOC/REV to intercept and track the localizer course outbound to the procedure turn area.
- (c). Engage HDG mode on autopilot console to engage coupler.

ILS/Back Course

- (a) Set inbound, front, localizer course on H.S.I.
- (b) Select LOC/REV on Radio Coupler to intercept and track inbound on the back localizer course. Select LOC/NORM to intercept and track outbound on the back course to the procedure turn area.
- (c) Engage HDG mode on autopilot console to engage coupler.

(5) Radio Coupling VOR/ILS with Standard Directional Gyro - (Optional)

NOTE

Radio Coupler operation in conjunction with a standard Directional Gyro and VOR/LOC display differs from operation with an integrated display (H.S.I.) only in one respect. The Heading Bug is used as the radio course datum and therefore must be set to match the desired VOR course as selected on the O.B.S.

- (a) For VOR Intercepts and Tracking: Select the desired VOR course and set the Heading Bug to the same heading. Select OMNI mode on the coupler and engage the HDG mode on the autopilot console.
- (b) For ILS Front Course Intercepts and Tracking: Tune the localizer frequency and place the Heading Bug on the inbound front course heading. Select LOC/NORM on the coupler and engage HDG mode on the autopilot console.
- (c) For LOC Back Course Intercepts and Tracking: Tune the localizer frequency and place the Heading Bug on the inbound course heading to the airport. Select LOC/REV mode on the coupler and engage HDG mode on the autopilot console.

### 3. EMERGENCY OPERATION

- a. In an emergency the AutoControl HIB can be disconnected by:
  - (1) Placing the A/P ON/OFF switch to the "OFF" position.
  - (2) Pulling the A/P circuit breaker.
- b. The Autopilot can be overpowered at either control wheel.
- c. An Autopilot runaway, with a 3 second delay in the initiation of recovery while operating in climb, cruise or descending flight, could result in a 55° bank and 225 foot altitude loss.
- d. An Autopilot runaway, with a 1 second delay in the initiation of recovery, during an approach operation, coupled or uncoupled, single or multi-engine could result in an 18° bank and 30 foot altitude loss.

### 4. PERFORMANCE

No change.

FAA APPROVED October 1, 1974

REPORT: 1630 PART I PAGE 59  
MODEL: PA-23-250 (Six Place)  
SN 27-4426, 27-4574 and up

AZTEC "E"

---

THIS PAGE INTENTIONALLY LEFT BLANK

REPORT: 1630 PART I PAGE 60  
MODEL: PA-23-250 (Six Place)  
SN 27-4426, 27-4574 and up

FAA APPROVED October 1, 1974

## 13. INSTALLATION OF PIPER ALTIMATIC IHC (Includes Roll, Pitch and Pitch Trim Sections)

## NOTE

The information contained herein supplements the information of the basic Airplane Flight Manual. For limitations, procedures and performance information not contained in this supplement consult the basic Airplane Flight Manual.

## 1. LIMITATIONS

- a. The maximum speed for autopilot operation is 215 MPH CAS. (Autopilot Vmo)
- b. Reduce autopilot Vmo 5 MPH CAS each 1000 feet above 21,000 feet.
- c. Use of flaps not authorized during autopilot operation.
- d. Autopilot "OFF" for takeoff and landing.
- e. Placard P/N 13A660 "Conduct Trim Check Prior to Flight (See AFM)" to be installed in clear view of pilot.
- f. During autopilot operation, the pilot must be in his seat with the safety belt fastened.

## 2. PROCEDURES

## a. PREFLIGHT

## (1) Roll Section

- (a) Place Radio Coupler in "Heading" mode and place Roll rocker switch in the "ON" position to engage roll section. Rotate Roll Command Knob left and right and observe that control wheel describes a corresponding left and right turn, then center Roll Command Knob.
- (b) Set proper D.G. Heading on D.G. and turn Heading Bug to aircraft heading. Engage HDG mode rocker switch and rotate Heading Bug right and left. Aircraft control wheel should turn same direction as Bug. Grasp control wheel and manually override servo, both directions.
- (c) Disengage Autopilot by depressing trim switch. Check Aileron operation is free and A/P is disconnected from controls.

## (2) Pitch Section

- (a) Engage "Roll" rocker switch.
- (b) Center pitch command disc and engage "Pitch" rocker switch.
- (c) Rotate pitch command disc full DOWN and full UP and check control wheel describes a corresponding fore and aft movement. Check to see that servo can be overridden by hand at control wheel.

## NOTE

Autopilot might not be able to raise elevators on ground without assistance from pilot.

- (d) Hold control wheel and disengage Autopilot by pressing Master A/P Disconnect/Trim Interrupt switch button. Check Roll and Pitch controls to assure autopilot has disconnected.

## (3) Trim Section (General)

This aircraft is equipped with a Command Trim System designed to withstand any type of single malfunction, either mechanical or electrical, without uncontrolled operation resulting. The preflight check procedure is designed to uncover hidden failures that might otherwise go undetected. Proper operation of the electric elevator trim system is predicated on conducting the following preflight check before each flight. If the trim system fails any portion of the procedure, pull the trim circuit breaker out until trim system is repaired. Substitution of any trim system component for another model is not authorized. For emergency interrupt information, refer to Section 2.d. of this supplement.

The Command Electric Trim Switch on the left hand portion of the pilot's control wheel has two functions:

- (a) When the top bar (A/P off) is pressed, it disconnects the Autopilot.
- (b) When the top bar is pressed and the rocker is moved forward, nose down trim will occur - when moved aft, nose up trim will occur.

## PREFLIGHT: Command Trim - Before Each Flight

- (a) Check trim circuit breaker - IN.
- (b) Trim Master Switch - ON.
- (c) A/P OFF - Check normal trim operation - UP. Grasp trim crank and check override capability. Check nose DOWN operation. Recheck override.
- (d) With trim operating - depress interrupt switch - trim should stop - release interrupt switch - trim should operate.
- (e) Activate center bar only - push rocker fore and aft - only. Trim should not operate with either separate action.

## AUTOTRIM - Before Each Flight

- (a) A/P ON - (Roll and Pitch Sections) Check automatic operation by activating A/P Pitch Command Disc UP, then DN. Observe trim operation follows Pitch Command Direction.

## NOTE

In Autopilot Mode, there will be approximately a 3 second delay between operation of Pitch Command and operation of trim.

- (b) Press center bar (A/P OFF) - release - check autopilot disengagement.
- (c) Rotate trim crank to check manual trim operation. Reset to takeoff position prior to takeoff.

## b. IN-FLIGHT

- (1) Trim airplane (ball centered).
- (2) Check air pressure or vacuum to ascertain that the Directional Gyro and Attitude Gyro are receiving sufficient air.

- (3) Roll Section
- To engage, center Roll Command Knob, push Roll rocker switch to the "ON" position. To turn, rotate Roll Command Knob in desired direction. (Maximum angle of bank should not exceed 30°.)
  - For heading mode, set Directional Gyro with Magnetic Compass. Push directional gyro HDG knob in, rotate to select desired heading. Push HDG rocker switch to the "ON" position. (Maximum angle of bank will be 20° with heading lock engaged.)
- (4) Pitch Section - (Roll Section must be engaged prior to engaging Pitch Section.)
- Center pitch trim indicator with the Pitch Command Disc.
  - Engage pitch rocker switch. To change attitude, rotate Pitch Command Disc in the desired direction.
- (5) Altitude Hold
- Upon reaching desired or cruising altitude, engage ALT Hold Mode rocker switch. For best results reduce rate of climb or descent to 500 FPM before engaging altitude hold mode.

## NOTE

Prior to disengaging Altitude Hold Mode, rotate Pitch Command Disc to center.

- (6) Radio Coupling VOR/ILS with H.S.I. (Horizontal Situation Indicator) Type Instrument Display. (Optional)
- VOR Navigation
- Tune and identify VOR Station. Select desired course by rotating CRS knob of H.S.I.
  - Select OMNI mode on Radio Coupler.
  - Engage HDG mode on autopilot console to engage coupler. Aircraft will turn to a 45° intercept angle to intercept the selected VOR course. Intercept angle magnitude depends on radio needle off-course magnitude, 100% needle deflection will result in 45° intercept angle, diminishing as the needle off-set diminishes.
  - NAV mode - NAV mode provides reduced VOR sensitivity for tracking weak, or noisy, VOR signals. NAV mode should be selected after the aircraft is established on course.
- ILS/LOC Front Course
- Set inbound, front, localizer course on H.S.I.
  - Select LOC/NORM mode on Radio Coupler to intercept and track inbound on the localizer. Select LOC/REV to intercept and track the localizer course outbound to the procedure turn area.
  - Engage HDG mode on autopilot console to engage coupler.
- ILS/Back Course
- Set inbound, front, localizer course on H.S.I.
  - Select LOC/REV on Radio Coupler to intercept and track inbound on the back localizer course. Select LOC/NORM to intercept and track outbound on the back course to the procedure turn area.
  - Engage HDG mode on autopilot console to engage coupler.



(7) Radio Coupling - VOR/ILS with standard directional gyro (Optional)

Radio Coupler operation in conjunction with a standard directional gyro and VOR/LOC display differs from operation with an integrated display (HSI) only in one respect. The HDG bug is used as the radio course datum and therefore must be set to match the desired VOR/ILS course as selected on the OBS.

(a) For VOR Intercepts and Tracking:

Select the desired VOR Course and set the HDG bug to the same heading. Select OMNI mode on the coupler and HDG mode on the autopilot console.

(b) For ILS Front Course Intercepts and Tracking:

Tune the localizer frequency and place the HDG bug on the inbound, front course heading. Select LOC-NOR mode on the coupler and HDG mode on the autopilot console.

(c) For LOC Back Course Intercepts and Tracking:

Tune the localizer frequency and place the HDG bug on the inbound course heading to the airport. Select LOC REV mode with coupler and HDG mode on the autopilot console.

c. COUPLED APPROACH OPERATIONS

(1) VOR or LOC

(a) After arrival at the VOR Station, track outbound to the procedure turn area as described in Section b.(6) or (7), as appropriate.

(b) Use HDG mode and Pitch or ALT Hold modes as appropriate during procedure turn.

(c) At the F.A.F. inbound, return to pitch mode for control of descent and lower landing gear.

(d) At the M.D.A. engage ALT Hold mode and add power for level flight. Monitor Altimeter to assure accurate altitude control is being provided by the autopilot.

(e) Go-Around. For missed approach select desired pitch attitude with Pitch Command Disc and disengage ALT Hold mode. This will initiate the pitch up attitude change. Immediately add takeoff power and monitor Altimeter and rate of climb for positive climb indication. After climb is established, retract the flaps and landing gear. Adjust attitude as necessary for desired airspeed and engage HDG mode for turn from the VOR final approach course.

(2) ILS - Front Course Approach with Glide Slope Capture (Optional)

(a) Track inbound to L.O.M. as described in Section b.(6) or (7) with ALT Hold mode engaged.

(b) Inbound to L.O.M. Slow to 120 MPH IAS.

(c) Automatic Glide Slope capture will occur at Glide Slope Intercept if the following conditions are met:

1. Radio Coupler in LOC/NORM Mode.
2. Altitude Hold Mode engaged (ALT rocker switch on console).
3. Under Glide Slope for more than 20 seconds.
4. Localizer radio frequency selected on NAV receiver.

- (d) At Glide Slope Intercept immediately lower landing gear and reduce power to maintain 120 MPH on final approach. Glide Slope capture is indicated by lighting of the green Glide Slope engage Annunciator Lamp and by a slight pitch down of the aircraft.
- (e) Monitor localizer and Glide Slope raw data through out approach. Adjust power as necessary to maintain correct final approach airspeed. All power changes should be of small magnitude and smoothly applied for best tracking performance. Do not change aircraft configuration during approach while autopilot is engaged.
- (f) Conduct missed approach maneuver as described in Section c.(1)(e).

## NOTE

Glide Slope Coupler will not automatically decouple from Glide Slope. Decoupling may be accomplished by any of the following means:

- (1) Disengage ALT Hold mode.
- (2) Switch Radio Coupler to HDG mode.
- (3) Disengage Autopilot.

## d. EMERGENCY OPERATIONS

This aircraft is equipped with a Master Disconnect/Interrupt Switch on the pilot's control wheel. When the switch button is depressed it will disconnect the autopilot. When depressed and held it will interrupt all Electric Elevator Trim Operations. Trim operation will be restored when the switch is released. If an autopilot or trim emergency is encountered, do not attempt to determine which system is at fault. Immediately depress and hold the Master Disconnect/Interrupt button. Turn off Autopilot and Trim Master Switch and retrim aircraft, then release the interrupt switch.

## NOTE

During examination of this supplement, the pilot is advised to locate and identify the Autopilot controls, the Trim Master Switch and the Circuit Breakers for both systems.

- (1) In the event of an Autopilot malfunction the Autopilot can be:
  - (a) Overpowered at either control wheel.

## CAUTION

Do not overpower Autopilot pitch axis for periods longer than 3 seconds because the Autotrim System will operate in a direction to oppose the pilot and will, thereby, cause an increase in the pitch overpower forces.

- (b) Disconnected by depressing the Master Disc/Inter Switch.
- (c) Disconnected by depressing the Trim Switch "A/P OFF" bar.
- (d) Disconnected by pushing the Roll rocker switch "OFF."
- (2) In the event of a Trim malfunction:
  - (a) Depress and hold the Master Trim Interrupt Switch.
  - (b) Trim Master Switch - OFF. Retrim aircraft as necessary using manual trim system.
  - (c) Release Master Trim Interrupt Switch - be alert for possible trim action.
  - (d) Trim Circuit Breaker - Pull. Do not operate trim until problem is corrected.
  - (e) If the trim system operates only in one direction, pull the circuit breaker and do not operate the trim system until corrective action is taken. Monitor autopilot operation closely when operating without trim follow-up.
- (3) If a trim runaway occurs with the Autopilot operating, the above procedures will disconnect the Autopilot which will immediately result in higher control wheel forces. Be prepared to manually retrim, as necessary, to eliminate undesirable forces.
- (4) Single Engine Operations
  - (a) Engine failure during an Autopilot approach operation: Disengage Autopilot conduct remainder of approach manually.
  - (b) Engine failure during Go-Around: Disengage Autopilot, retrim aircraft, perform normal aircraft engine out procedures then re-engage Autopilot.
  - (c) Engine failure during normal climb, cruise, descent: Retrim aircraft, perform normal aircraft engine out procedures.
  - (d) Maintain aircraft yaw trim throughout all single engine operations.
- (5) Altitude Loss During Malfunction
  - (a) An Autopilot malfunction during climb or cruise with a 3 second delay in recovery initiation could result in as much as 60° of bank and 420 foot altitude loss.
  - (b) Altitude loss - high altitude descent - 3 second delay in recovery could result in a 35° bank and a 600 foot altitude loss.
  - (c) An Autopilot malfunction during an approach with a 1 second delay in recovery initiation could result in as much as 20° of bank and a 100 foot altitude loss. Maximum altitude loss measured in approach configuration gear down and operating either coupled or uncoupled, single or multi-engine.
- (6) Emergency Operation With Optional NSD 360A (HSI) Slaved and or Non-Slaved:

NSD 306A

- (a) Appearance of HDG Flag:
  1. Check air supply gauge (vac or pressure) for adequate air supply (4 in. Hg. min.).
  2. Check compass circuit breaker.
  3. Observe display for proper operation.
- (b) To disable heading card - pull circuit breaker and use magnetic compass for directional data.

NOTE

If heading card is not operational, autopilot should not be used.

- (c) With card disabled VOR/Localizer and Glide Slope displays are still functional; use card set to rotate card to aircraft heading for correct picture.
- (d) Slaving Failure - (i.e. failure to self correct for gyro drift):
1. Check gyro slaving switch is set to No. 1 position (if equipped with Slave No. 1 - No. 2 switch) or "Slaved" position when equipped with Slaved and Free Gyro Mode Switch.
  2. Check for HDG Flag.
  3. Check compass circuit breaker.
  4. Reset heading card while observing slaving meter.

## NOTE

Dead slaving meter needle or a needle displaced fully one direction indicates a slaving system failure.

5. Select slaving amplifier No. 2, if equipped. If not equipped, proceed with No. 7 below.
6. Reset heading card while checking slaving meter. If proper slaving indication is not obtained,
7. Switch to free gyro mode and periodically set card as an unslaved gyro.

## NOTE

In the localizer mode, the "TO-FROM" arrows may remain out of view, depending upon the design of the NAV converter used in the installation.

### 3. PERFORMANCE

No change

# EMERGENCY PROCEDURES

Engine Failure In Flight and Feathering Procedure .....	1
Engine Failure During Take-Off .....	1
Unfeathering .....	2
Emergency Landings .....	3
Emergency Landing Gear Extension .....	3
In-Flight Cabin Door Closing Procedure .....	4
Emergency Exit Window .....	4
Emergency Descent .....	4

## EMERGENCY PROCEDURES

## 1. Engine Failure In Flight And Feathering Procedure:

As the engine loses power, a slight yaw in the direction of the dead engine will occur, which can be corrected easily with the rudder or the rudder trim tab. While the plane is slowing down to the single engine cruising speed of about 138 MPH at low altitudes and at moderate power settings, the propeller on the dead engine should be feathered by pulling the throttle to idling position and the prop pitch control back fully; then the mixture should be set at idle cut-off, cowl flap closed and the ignition off. The cowl flap on the operative engine should be adjusted to maintain proper cylinder head temperature. Best single engine performance will be obtained with the dead engine wing held up about 5 degrees higher than level. This helps counteract the tendency to turn in that direction.

## NOTE

If vacuum operated copilot gyros are installed, turn copilot gyro switch off during single engine operation or in event of vacuum pump failure.

## CAUTION

If the left engine has failed, the hydraulic pump will not be functioning. If it is necessary to lower the landing gear or flaps with the left engine dead, the hydraulic hand pump located in the pedestal is used. (See 5, this section.)

## 2. Engine Failure During Take-Off:

The Hartzell feathering propellers can only be feathered while the failed engine is rotating, and not if the engine drops below 1000 RPM. The loss of centrifugal force due to slow RPM count will activate a stop pin that keeps the propeller from feathering each time the engine is shut down on the ground. If an engine freezes up, it will be impossible to feather its propeller. Single engine flight can be maintained with the dead engine propeller unfeathered, although a noticeable decrease in single engine performance will take place.

If an engine failure occurs during take-off run, the power on the good engine should be cut and the airplane stopped straight ahead. If it occurs after leaving the ground, but with sufficient landing area still ahead, a landing should be effected immediately. If no landing can be made directly after the failure, the following steps should be followed:

- a. Apply full power to good engine.
- b. Feather dead engine.
- c. Retract landing gear and flaps, if extended (using hand pump if left engine is out). If enough altitude has been reached for reaching the airport with the gear extended, leave the landing gear in the down position.
- d. Maintain a best rate of climb airspeed.
- e. Trim directionally with rudder trim.
- f. As the airport is approached for landing, reduce power on the good engine and gradually retrim with the rudder tab. When it is obvious that the airport can be reached easily, lower the landing gear and check the indicators to make sure it is down and locked. Maintain a little extra altitude and speed during the approach, keeping in mind that the landing should be made right the first time, and that either undershooting or overshooting may require the use of full power on the good engine, making control more difficult. Lower the flaps at the last moment if desired.

## NOTE

The aircraft may not climb at speeds below best single engine rate of climb speed.

If the left engine is inoperative, operation of the gear and flaps is limited to the use of the hand pump (refer to Emergency Landing Gear Extension).

## 3. Unfeathering:

It is not recommended that propeller feathering and unfeathering be practiced on the ground because of the excessive vibration that occurs in the engine installation. In flight, feathering should be practiced only to familiarize the pilot with the proper procedures. To unfeather a propeller in flight, the following technique is recommended:

- a. Turn main fuel valve "ON."
- b. Turn ignition switches "ON."
- c. Prime engine if necessary, then turn electric fuel pump off.
- d. Open throttle 1/2 inch.
- e. Advance propeller control to high RPM position.
- f. Advance mixture control to full rich.
- g. Engage starter.
- h. As RPM passes 1000 coming out of feather, retard propeller control to maintain 1800-2000 RPM for warm-up. Adjust manifold pressure to 15" and maintain this low power until oil temperature begins to rise and oil pressure can be maintained within limits.
- i. Re-synchronize engines.

If the engine has been inoperative for several minutes, particularly in low temperatures, prime by turning the boost pump "ON" and moving the mixture control forward until the first indication of fuel pressure; then return to "IDLE CUT-OFF." Leave boost pump "ON" and continue start as in (d) above.

Operating at gross weight under optimum conditions of turbulence and pilot technique, and under standard conditions of temperature and altitude, the Turbo Aztec has a single engine absolute ceiling of 18,700 feet at 5200 pounds and maximum attainable power. The normally aspirated Aztec has a single engine absolute ceiling of 6,400 feet at 5200 pounds and maximum attainable power.

Under ideal conditions, the Aztec can be expected to maintain approximately the stated maximum altitudes. When adverse conditions of turbulence, temperature, altitude, pilot technique, or airplane condition or equipment is encountered, the absolute ceiling will be reduced. These factors must be taken into consideration in the single engine operation of any twin engine airplane.

Pilots of this airplane should remain reasonably proficient in single engine flight. In many cases, "simulated" single engine operation (zero thrust condition, approximately 11 inches of manifold pressure and 2175 RPM) will be preferable, but actual single engine operation should be practiced occasionally. The following precautions should be exercised in actual single engine flight:

- a. Do not feather a propeller if there is reason to suspect that the starting characteristics of the engine are not normal and that restarting in the air may be difficult or impossible.
- b. Do not feather a propeller in conditions of temperature, altitude, weight or turbulence which may prevent single engine flight at altitudes well above the local ground elevation.
- c. Do not feather a propeller at any time when conditions of terrain or other conditions may prevent the airplane from reaching an airport easily, in case the dead engine cannot be restarted.
- d. Do not practice single engine operation without a well qualified pilot in one of the forward seats. The pilot must hold a multi-engine rating and have familiarity with Aztec procedures and characteristics.

#### 4. Emergency Landings:

On a wheels-up landing, the airplane will tend to settle down at the rear when the landing speed is decreasing, and full forward control wheel pressure should be used to hold the tail up as long as possible. The flaps should not be extended because they may contact the ground first, causing damage to the flap and the wing. The propellers should be feathered and stopped in a horizontal position. Fuel valves and electrical switches should be turned to off position.

A wheels-up landing should only be made during an emergency when the surface is too soft or too rough to permit a gear-down landing, or when an emergency water landing is necessary.

#### 5. Emergency Landing Gear Extension:

If the left engine or engine driven hydraulic pump fails, extend the landing gear or flaps by supplying hydraulic pressure with the manual hydraulic pump. With the gear or flap control in the desired position, about 50 strokes of the pump handle will raise or lower the landing gear. An additional 15 strokes will raise or extend the flaps. Manual pumping is increasingly difficult as the gear draws closer to full extension or retraction. Note position of the gear by the position lights and left cowl mirror and not by the gear control knob alone, as hydraulic pressure may cause the control handle to flip into neutral before the gear is in position and locked.

In the event of hydraulic system failure caused by a line breaking or the power pack malfunctioning, the landing gear can be lowered by using the Emergency Gear Extender. The control for the extender is located beneath a small cover plate under the pilot's seat. When this control is pulled, CO<sub>2</sub> flows from a cylinder under the floorboards through separate lines to shuttle valves adjacent to the gear extension cylinders. The gas pressure opens the shuttle valves, allowing CO<sub>2</sub> to enter the gear cylinders, extending the gears.

The Emergency Gear Extender should only be used when all other means of lowering the landing gear have failed, and only when the gear can be left down for landing.

#### NOTE

The landing gear control on the selector valve must be in the "down" position when the gear extender control is pulled, in order to allow the gear to be extended properly.

#### CAUTION

When the extender has been used, the landing gear or flaps must not be actuated hydraulically in any way until the extension system has been returned to its normal condition.



6. In-Flight Cabin Door Closing Procedure:

In the event the cabin door is inadvertently unlocked in flight or the handle is not pushed forward and locked before take-off and becomes dislodged from its latching position, the following procedure has been determined to be practicable for closing the cabin door while in flight, assuming adequate altitude has been attained.

- a. Retard throttles.
- b. Reduce airspeed to 90 MPH or less.
- c. Open storm window (left of pilot).
- d. Close door.
- e. Recover power and airspeed.

Other conditions, take-off, landing approach, and general low altitude flight will require action at the discretion of the pilot.

7. Emergency Exit Window:

Provided in the left side of the fuselage adjacent to the left center seat is an emergency exit window. The window is sealed when installed and should be removed only in case of emergency.

To remove window:

- a. Remove plastic placard.
- b. Turn handle.
- c. With hands apart on bottom sill, apply a steady sustained pressure outward until window is dislodged.

8. Emergency Descent:

In the event of an oxygen system failure or some other condition dictating a rapid descent to 10,000 feet or below, close the throttles, move propellers to full increase RPM, close cowl flaps, retract gear and flaps and maintain 198 IAS. Speeds to VNE are permissible in smooth air.

NOTES

Assurance that the airplane is in an airworthy condition is the responsibility of the owner. The pilot in command is responsible for determining that the airplane is safe for flight. The pilot is also responsible for remaining within the operating limitations outlined by the Flight Manual, instrument markings, and placards.

This Pilot's Operating Manual is not designed, nor can any operating manual serve, as a substitute for adequate and competent flight instruction, or knowledge of the current airworthiness directives, the applicable federal air regulations, and advisory circulars. It is not intended to be a guide of basic flight instruction, nor a training manual for transition from single engine flying to multi-engine flying.

If there is any inconsistency between the Airplane Flight Manual approved by the FAA, and the additional information in this manual the Airplane Flight Manual shall govern.

Additional copies of this manual, Part No. 761 455, may be obtained from your Piper Dealer.

Published by  
PUBLICATIONS DEPARTMENT  
Piper Aircraft Corporation  
761 455  
Issued: September 1970

# WEIGHT AND BALANCE

# WEIGHT AND BALANCE

Table of Contents	i
Empty Weight (Serial Nos. 27-4426, 27-4574 thru 27-7405476)	2
Basic Weight (Serial Nos. 27-4426, 27-4574 thru 27-7405476)	2
General Loading Recommendations (Serial Nos. 27-4426, 27-4574 thru 27-7405476)	3
Weight and Balance - Visual Plotter (Serial Nos. 27-4426, 27-4574 thru 27-7405476)	4
Summary of Disposable Load (Serial Nos. 27-4426, 27-4574 thru 27-7405476)	6
Empty Weight (Serial Nos. 27-7554001 and up)	7
Basic Weight (Serial Nos. 27-7554001 and up)	7
General Loading Recommendations (Serial Nos. 27-7554001 and up)	8
Weight and Balance - Visual Plotter (Serial Nos. 27-7554001 and up)	8a
Summary of Disposable Load (Serial Nos. 27-7554001 and up)	8c
Cargo Loading	8d
Equipment List	9

## TABLE OF CONTENTS

Empty Weight (Serial Nos. 27-4426, 27-4574 thru 27-7405476)	2
Basic Weight (Serial Nos. 27-4426, 27-4574 thru 27-7405476)	2
General Loading Recommendations (Serial Nos. 27-4426, 27-4574 thru 27-7405476)	3
Weight and Balance - Visual Plotter (Serial Nos. 27-4426, 27-4574 thru 27-7405476)	4
Summary of Disposable Load (Serial Nos. 27-4426, 27-4574 thru 27-7405476)	6
Empty Weight (Serial Nos. 27-7554001 and up)	7
Basic Weight (Serial Nos. 27-7554001 and up)	7
General Loading Recommendations (Serial Nos. 27-7554001 and up)	8
Weight and Balance - Visual Plotter (Serial Nos. 27-7554001 and up)	8a
Summary of Disposable Load (Serial Nos. 27-7554001 and up)	8c
Cargo Loading	8d
Equipment List	9
A. Propellers and Propeller Accessories	9
B. Engines and Engine Accessories - Fuel and Oil Systems	11
C. Landing Gear	12
D. Electrical Equipment	13
E. Interior Equipment	14
F. Combustion Heater	15
G. Autopilot	15
H. Instruments (Standard and Optional)	16a
I. Deicing Equipment	16c
J. Miscellaneous Equipment	17
K. Optional Equipment	18
L. Shoulder Harness	21
M. Radio	22

ISSUED: October 1, 1974  
 REVISED: January 22, 1975

REPORT: 1630 PART II PAGE i  
 MODEL: PA-23-250 (Six Place)  
 SN 27-4426, 27-4574 and up

GENERAL LOADING RECOMMENDATIONS: (serial nos. 27-4426, 27-4574 thru 27-7405476)

## Load Occupants From Front to Rear Progressively

## Pilot Only

Load rear baggage compartment to capacity first.

## 2 Occupants - Pilot and passenger in front.

Load rear baggage compartment to capacity first. Baggage in nose limited by envelope with full fuel.

## 3 Occupants - 2 in front, 1 in middle.

Load rear baggage compartment to capacity first. Baggage in nose limited by envelope with full fuel.

## 4 Occupants - 2 in front, 2 in middle.

Load rear baggage compartment to capacity first. Baggage in nose limited by envelope with full fuel.

## 5 Occupants - 2 in front, 2 in middle, 1 in rear.

Forward and rearward baggage limited by envelope with full fuel. With 2 full tanks of fuel, load rear baggage compartment first.

## 5 Occupants - 1 in front, 2 in middle, 2 in rear.

Permitted only with special loading investigation.

## 6 Occupants - 2 in front, 2 in middle, 2 in rear.

6 occupants permitted only with limited fuel or baggage. Load forward baggage compartment to capacity first.

The preceding general loading recommendations are based on an airplane with the Narco Radio Package and a Piper Altimatic Pilot or their equivalent in ballast installed. These recommendations will indicate to the pilot the proper loading procedure. They will advise if a special loading check is required for his particular loading to assure its remaining in the weight vs. center of gravity envelope as given on Page 5.

The Narco radio package consists of the following units: (Weights and arms may be found in the equipment lists in the following pages.)

Bendix ADF-T-12C

Two of Narco Mark 12 with VOA-8

PM-1 Marker Beacon

Special loading investigations are required for airplanes with other weight configurations.

## NOTE

The special loading investigations may be made using the charts, graphs and instructions on the following pages.

ISSUED: January 21, 1970  
REVISED: October 1, 1974

REPORT: 1630 PART II PAGE 3  
MODEL: PA-23-250 (Six Place)  
SN 27-4426, 27-4574 and up

PA-23-250 (SIX PLACE) AZTEC  
WEIGHT AND BALANCE – VISUAL PLOTTER  
(Serial nos. 27-4426, 27-4574 thru 27-7405476)

The chart showing the approved Weight vs. Center of Gravity envelope and the Visual Plotter contained in the following pages will enable the pilot to graphically determine whether or not his proposed loading will fall within the allowable envelope. They will also allow him to easily determine the necessary adjustments to make if his first proposed loading is not within this envelope.

When plotting successive points, the pilot is graphically adding weights and corresponding moments. As the weight increases, through the addition of various items of disposable load, the pilot will see the shift in the center of gravity.

Going clockwise around the envelope, the heavy lines represent allowable weight at the forward C.G. limit (85.7 in.), the maximum allowable weight as the C.G. shifts rearward, the maximum weight with no fuel, the gross weight (5200 lbs.), and the maximum rearward C.G. limit (100.5 in.).

The sample problem which follows, will demonstrate the use of the Visual Plotter included with this manual. The pilot is not restricted to adding the items in the same succession as outlined, since the sample problem illustrates only one of many possible loadings. When plotting successive items of disposable load, the items most important to the mission under consideration (range or payload) may be added first.

Before arranging his load, the pilot should consult the General Loading Recommendations.

IT IS THE RESPONSIBILITY OF THE OWNER AND PILOT TO ASCERTAIN THAT THE AIRPLANE ALWAYS REMAINS WITHIN THE ALLOWABLE WEIGHT VS. CENTER OF GRAVITY ENVELOPE WHILE IN FLIGHT.

SAMPLE PROBLEM  
(Serial nos. 27-4426, 27-4574 thru 27-7405476)

Assume (for demonstration purposes only) a Basic Weight and C.G. of 3090 pounds at 90.4 inches. Assume the disposable load to consist of pilot and five 170 pound passengers, 290 pounds baggage and maximum allowable fuel. The General Loading Recommendations on Page 3 advise loading forward baggage compartment to capacity first (150 pounds).

- (1) On the Weight vs. C.G. Envelope opposite 3090 pounds locate the C.G. at 90.4 inches (Point 1). This point represents the Basic empty airplane with oil and 4 gallons of unusable fuel included.
- (2) Lay the transparent Visual Plotter over the envelope (always keep BASE LINES parallel to horizontal or Weight ordinates) and plot along the proper scale the combined weights of the front seat occupants (340 pounds - Point 2).
- (3) From Point 2, following the proper scale of the Visual Plotter, plot the combined weights of the middle seat occupants (340 pounds) and mark Point 3.
- (4) From Point 3, again following the proper scale of the Visual Plotter, plot the combined weights of the rear seat occupants (340 pounds) and mark Point 4.
- (5) From Point 4 plot in succession, the proper distances (Use correct scale of Visual Plotter for each) which represent successive addition of forward and then rear baggage and finally fuel. (Points 5, 6, and 7.)

NOTE

The maximum zero fuel gross weight limitation of 4400 pounds restricts the rear baggage load to 140 pounds.



- (6) When the final step of adding fuel is plotted, the point falls within the envelope at 5141 pounds and 100.5 inches aft of datum. (The fuel graduations on the plotter run from 0 to 140 gallons. The tanks will always contain 4 gallons of unusable fuel, and these two figures total to the listed tank capacity of 144 gallons.)

NOTE

The addition of fuel to gross weight of 5200 pounds is restricted by the aft C.G. limitation of 100.5 inches. In this case fuel would be limited to approximately 133 gallons.

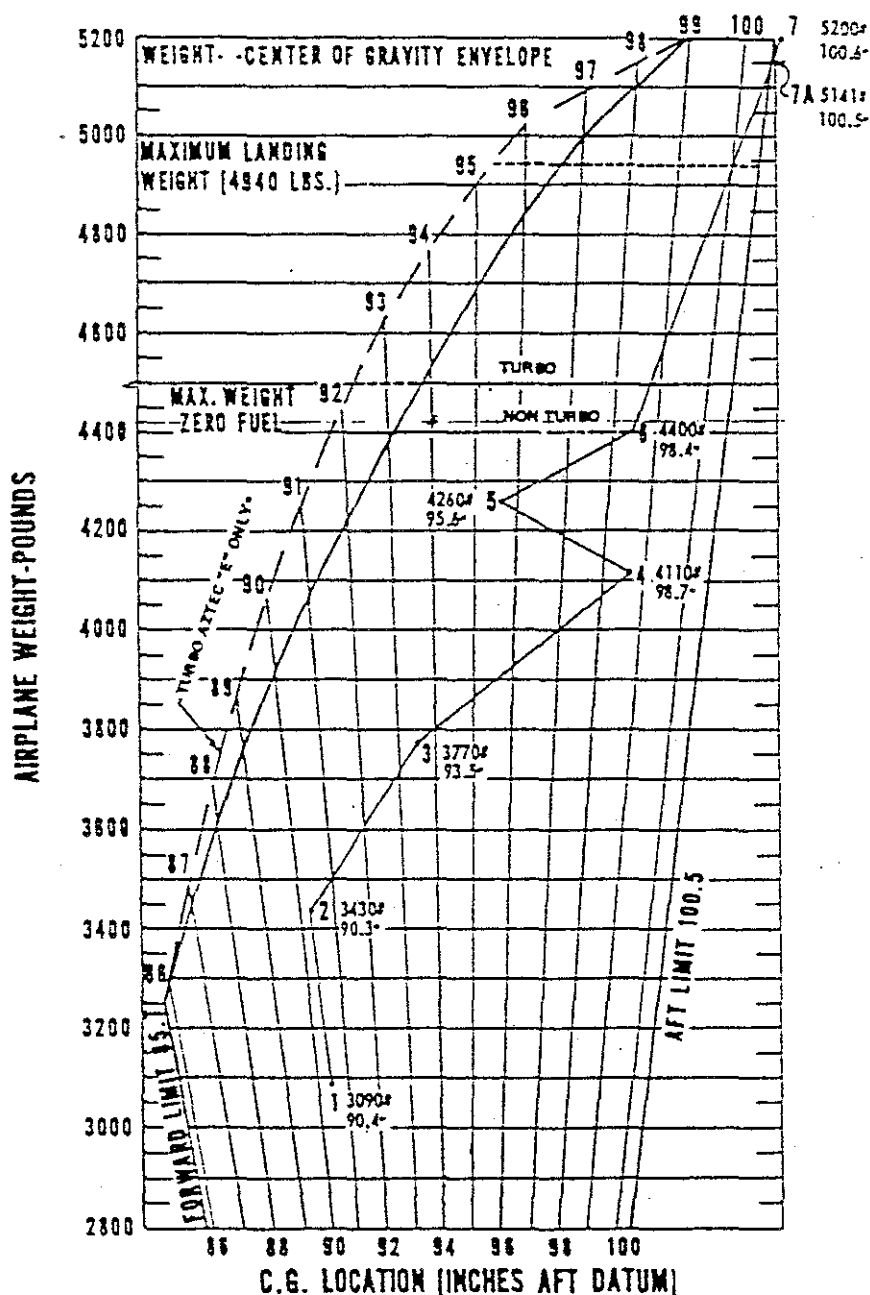

\*DASHED FORWARD ENVELOPE APPLICABLE ONLY FOR TURBO AZTEC "E", S/N 27-4781 AND SUBSEQUENT, OR TURBO AZTEC "E" PRIOR TO S/N 27-4781 IF SERVICE KIT 760 587 HAS BEEN INSTALLED.

ISSUED: January 21, 1970  
 REVISED: December 10, 1971

REPORT: 1630 PART II PAGE 5  
 MODEL: PA-23-250 (Six Place)  
 SN 27-4426, 27-4574 and up

## WEIGHT AND BALANCE

SUMMARY OF DISPOSABLE LOAD  
(Serial nos. 27-4426, 27-4574, thru 27-7405476)

When seats are removed for cargo stowage, the Basic Weight and corresponding C.G. must be corrected prior to determination of the loading schedule. The weights and arms for these seats are:

Item	Weight	Arm	Moment
Copilot's Seat and Headrest	23	89	2047
Middle Seat & Headrest (each)	23	126	2895
Rear Seat (Total)	27.5	157	4318

The normal disposable load items and arms are:

Item	Weight	Arm	Moment
Front Occupants	Use Actual	89	—
Middle Occupants	Use Actual	126	—
Rear Occupants	Use Actual	157	—
Forward Baggage	(150 Max.)	10	—
Rear Baggage	(150 Max.)	183	—
Fuel (36 gal. each tank)	216	113	24408
Fuel (140 gal. total)*	840*	113	94920

\* 4 gal. of unusable fuel is already included in Empty and Basic Weight and C.G. determinations.  
Total fuel capacity 144 gal.

EMPTY WEIGHT C.G. AS WEIGHED (serial nos. 27-7554001 and up)

Empty Weight C.G. Forward Main Wheel C.L. is:

$$A. \frac{(N)}{(T)} \times 90 = \text{ inches}$$

Empty Weight C.G. Aft Wing Leading Edge is:

$$B. 34.5 - (A) = \text{ inches}$$

Empty Weight C.G. Aft Datum is:

$$C. 80.0 + (B) = \text{ inches}$$

EMPTY WEIGHT AND C.G. WITH UNUSABLE FUEL (serial nos. 27-7554001 and up)

<u>Item</u>	<u>Weight</u>	<u>Arm</u>	<u>Moment</u>
Empty Weight as Weighed			
Unusable Fuel (6.8 Gal.)	<u>41</u>	<u>113</u>	<u>4633</u>
TOTAL			

Empty Weight and C.G. are          lbs. at          inches aft datum.

BASIC WEIGHT AND C.G. (serial nos. 27-7554001 and up)

(With unusable fuel and oil - for use with Visual Plotter, and Weight vs. C.G. Chart.)

The following calculation is performed here for simplicity to aid the pilot in his calculations. This weight will be referred to as "Basic Weight."

<u>Item</u>	<u>Weight</u>	<u>Arm</u>	<u>Moment</u>
Empty Weight			
Oil (6 Gal.)	45	55.0 =	2475
Unusable Fuel (6.8 Gal.)	<u>41</u>	<u>113.0 =</u>	<u>4633</u>
TOTAL			

Basic Weight and C.G. are          lbs. at          inches aft datum.

## NOTES

1. The Empty and Basic Weights include 6.8 gallons of unusable fuel (at 6.0 lbs. per gal. = 41 lbs. total). This fuel should not be considered part of the disposable load which the pilot wishes to add to the airplane. However, any fuel beyond this amount which remains in the tanks from previous flights must be considered part of the disposable load.
2. Each engine has an oil capacity of 3 gallons (at 7.5 lbs. per gal. = 45 lbs. total).

ISSUED: January 21, 1970  
 REVISED: October 1, 1974

REPORT: 1630 PART II PAGE 7  
 MODEL: PA-23-250 (Six Place)  
 SN 27-4426, 27-4574 and up

GENERAL LOADING RECOMMENDATIONS: (serial nos. 27-7554001 and up)

Load Occupants From Front to Rear Progressively

Pilot Only

Load rear baggage compartment to capacity first.

2 Occupants - Pilot and passenger in front.

Load rear baggage compartment to capacity first. Baggage in nose limited by envelope with full fuel.

3 Occupants - 2 in front, 1 in middle.

Load rear baggage compartment to capacity first. Baggage in nose limited by envelope with full fuel.

4 Occupants - 2 in front, 2 in middle.

Load rear baggage compartment to capacity first. Baggage in nose limited by envelope with full fuel.

5 Occupants - 2 in front, 2 in middle, 1 in rear.

Forward and rearward baggage limited by envelope with full fuel. With 2 full tanks of fuel, load rear baggage compartment first.

5 Occupants - 1 in front, 2 in middle, 2 in rear.

Permitted only with special loading investigation.

6 Occupants - 2 in front, 2 in middle, 2 in rear.

6 occupants permitted only with limited fuel or baggage. Load forward baggage compartment to capacity first.

The preceding general loading recommendations are based on an airplane with the Narco Radio Package and a Piper Altimatic Pilot or their equivalent in ballast installed. These recommendations will indicate to the pilot the proper loading procedure. They will advise if a special loading check is required for his particular loading to assure its remaining in the weight vs. center of gravity envelope as given on Page 8b.

The Narco Radio Package consists of the following units: (Weights and arms may be found in the equipment lists in the following pages.)

Bendix ADF-T-12C

Two of Narco Mark 12 with VOA-8

PM-1 Marker Beacon

Special loading investigations are required for airplanes with other weight configurations.

NOTE

The special loading investigations may be made using the charts, graphs and instructions on the following pages.

PA-23-250 (SIX PLACE) AZTEC  
WEIGHT AND BALANCE – VISUAL PLOTTER  
(Serial nos. 27-7554001 and up)

The chart showing the approved Weight vs. Center of Gravity envelope and the Visual Plotter contained in the following pages will enable the pilot to graphically determine whether or not his proposed loading will fall within the allowable envelope. They will also allow him to easily determine the necessary adjustments to make if his first proposed loading is not within this envelope.

When plotting successive points, the pilot is graphically adding weights and corresponding moments. As the weight increases, through the addition of various items of disposable load, the pilot will see the shift in the center of gravity.

Going clockwise around the envelope, the heavy lines represent allowable weight at the forward C.G. limit (85.7 in.), the maximum allowable weight as the C.G. shifts rearward, the maximum weight with no fuel, the gross weight (5200 lbs.), and the maximum rearward C.G. limit (100.5 in.).

The sample problem which follows, will demonstrate the use of the Visual Plotter included with this manual. The pilot is not restricted to adding the items in the same succession as outlined, since the sample problem illustrates only one of many possible loadings. When plotting successive items of disposable load, the items most important to the mission under consideration (range or payload) may be added first.

Before arranging his load, the pilot should consult the General Loading Recommendations.

IT IS THE RESPONSIBILITY OF THE OWNER AND PILOT TO ASCERTAIN THAT THE AIRPLANE ALWAYS REMAINS WITHIN THE ALLOWABLE WEIGHT VS. CENTER OF GRAVITY ENVELOPE WHILE IN FLIGHT.

SAMPLE PROBLEM  
(Serial nos. 27-7554001 and up)

Assume (for demonstration purposes only) a Basic Weight and C.G. of 3090 pounds at 90.4 inches. Assume the disposable load to consist of pilot and five 170 pound passengers, 290 pounds baggage and maximum allowable fuel. The General Loading Recommendations on Page 8 advise loading forward baggage compartment to capacity first (150 pounds).

1. On the Weight vs. C.G. Envelope opposite 3090 pounds locate the C.G. at 90.4 inches (Point 1). This point represents the Basic empty airplane with oil and 6.8 gallons of unusable fuel included.
2. Lay the transparent Visual Plotter over the envelope (always keep BASE LINES parallel to horizontal or Weight ordinates) and plot along the proper scale the combined weights of the front seat occupants (340 pounds - Point 2).
3. From Point 2, following the proper scale of the Visual Plotter, plot the combined weights of the middle seat occupants (340 pounds) and mark Point 3.
4. From Point 3, again following the proper scale of the Visual Plotter, plot the combined weights of the rear seat occupants (340 pounds) and mark Point 4.
5. From Point 4 plot in succession, the proper distances (use correct scale of Visual Plotter for each) which represent successive addition of forward and then rear baggage and finally fuel. (Points 5, 6, and 7.)

NOTE

The maximum zero fuel gross weight limitation of 4400 pounds restricts the rear baggage load to 140 pounds.

ISSUED: October 1, 1974

REPORT: 1630 PART II PAGE 8a  
MODEL: PA-23-250 (Six Place)  
SN 27-4426, 27-4574 and up

- When the final step of adding fuel is plotted, the point falls within the envelope at 5141 pounds and 100.5 inches aft of datum. (The fuel graduations on the plotter run from 0 to 140 gallons. The tanks will always contain 6.8 gallons of unusable fuel, the usable fuel is 137.2 gallons for a total tank capacity of 144 gallons.)

NOTE

The addition of fuel to gross weight of 5200 pounds is restricted by the aft C.G. limitation of 100.5 inches. In this case fuel would be limited to approximately 133 gallons.

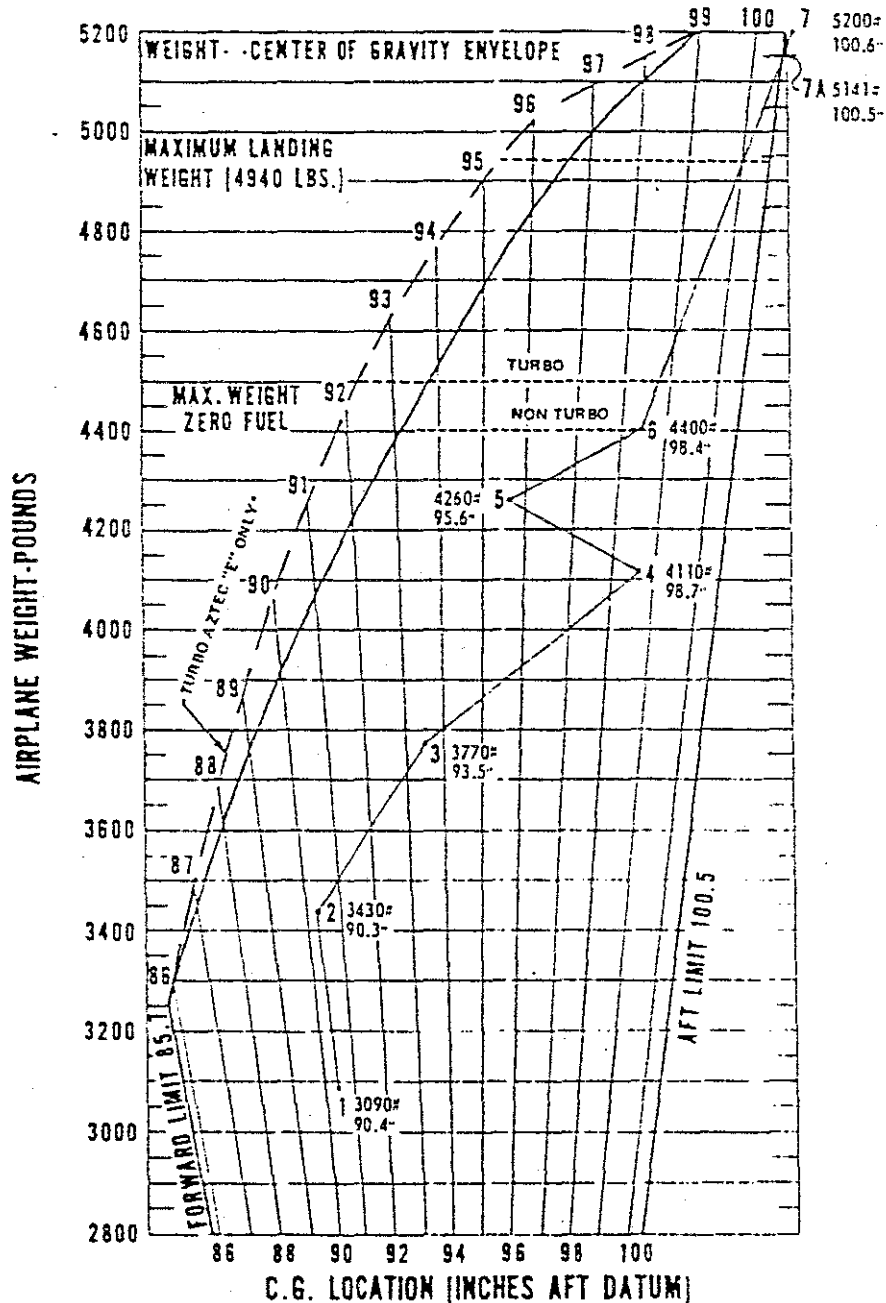

\*DASHED FORWARD ENVELOPE APPLICABLE ONLY FOR TURBO AZTEC "E," S/N 27-4781 AND SUBSEQUENT, OR TURBO AZTEC "E" PRIOR TO S/N 27-4781 IF SERVICE KIT 760 587 HAS BEEN INSTALLED.

## WEIGHT AND BALANCE

SUMMARY OF DISPOSABLE LOAD  
(Serial nos. 27-7554001 and up)

When seats are removed for cargo stowage, the Basic Weight and corresponding C.G. must be corrected prior to determination of the loading schedule. The weights and arms for these seats are:

Item	Weight	Arm	Moment
Copilot's Seat and Headrest	23	89	2047
Middle Seat & Headrest (each)	23	126	2898
Rear Seat (Total)	27.5	157	4318

The normal disposable load items and arms are:

Item	Weight	Arm	Moment
Front Occupants	Use Actual	89	—
Middle Occupants	Use Actual	126	—
Rear Occupants	Use Actual	157	—
Forward Baggage	(150 Max.)	10	—
Rear Baggage	(150 Max.)	183	—
Fuel (137 gal. total)*	823*	113	92999

\* 6.8 gal. of unusable fuel is already included in Empty and Basic Weight and C.G. determinations.  
Total fuel capacity 144 gal. (36 gal. each tank)

ISSUED: October 1, 1974  
REVISED: January 4, 1988

REPORT: 1630 PART II PAGE 8c  
MODEL: PA-23-250 (Six Place)  
SN 27-4426, 27-4574 and up

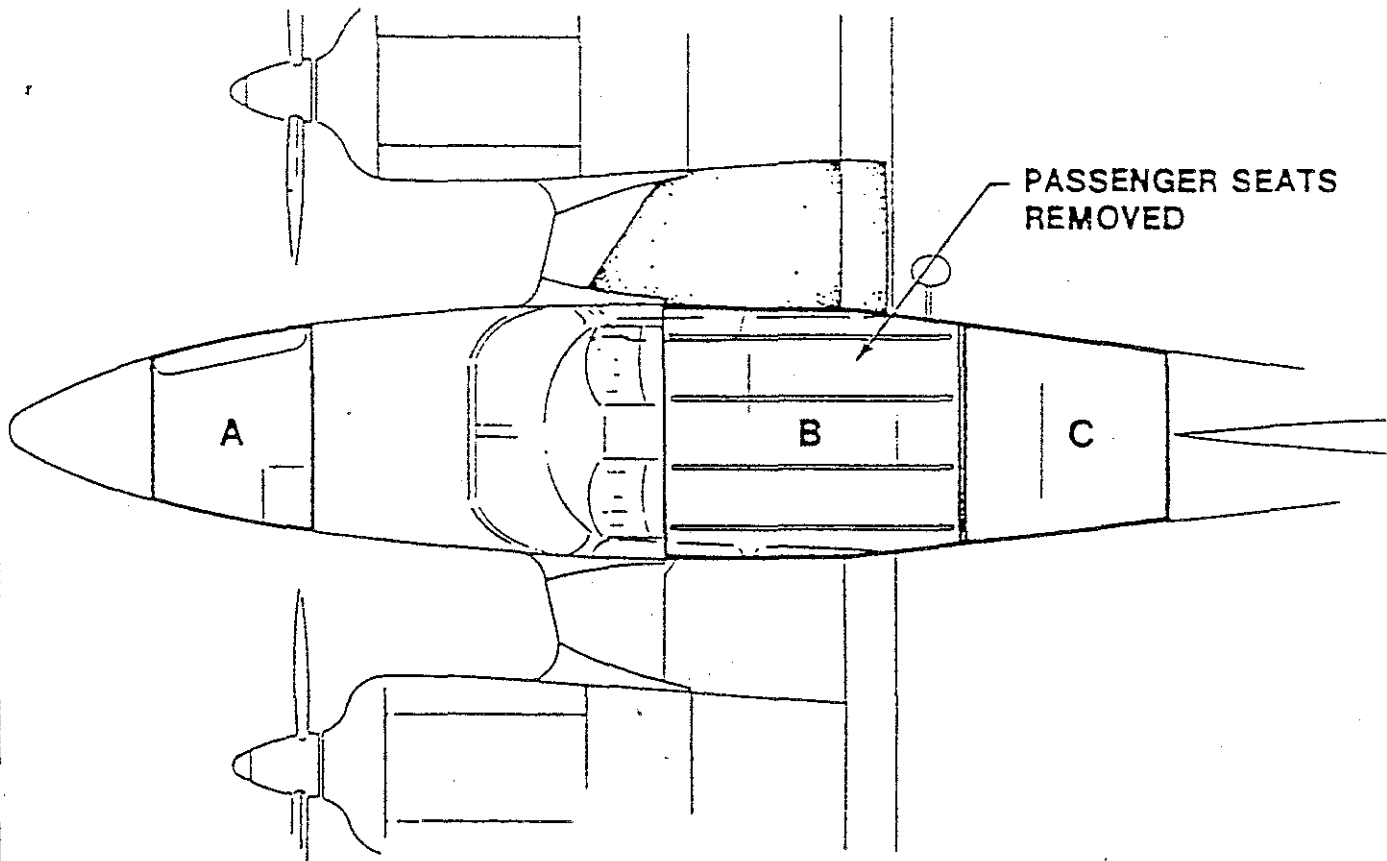

**MAXIMUM CAPACITY**

AREA	FLOOR LOAD LBS/SQ. FT.	ALLOWABLE LBS
A	100	150
B	43	820
C	100	*150 (INCLUDING 20 LBS ON SHELF)

\*105 LB. MAX. IF OXYGEN IS INSTALLED.

**MAXIMUM TIE DOWN CAPACITY**

PER TIE DOWN RING	95 LB
PER TRACK	190 LB
REAR SEAT BELT FITTINGS	85 LB PER FITTING

CARGO MUST BE LOADED WITHIN THE WEIGHT AND BALANCE LIMITS OF THIS AIRCRAFT.

Cargo Loading



## OPERATING TIPS

# OPERATING TIPS

Operating Tips ..... 1

## OPERATING TIPS

The following Operating Tips are of particular value in the operation of the Aztec:

1. Learn to trim for take-off so that only a very light back pressure on the wheel is required to rotate the airplane from the ground.
2. Due to the very rapid feathering action of the propeller on the Aztec, it will be necessary when feathering during ground check to move the propeller control in and out of feather position very quickly in order to prevent the RPM from dropping more than 500 RPM and causing excessive manifold pressure.
3. On take-off, do not retract the gear prematurely. The airplane may settle and make contact with the ground because of lack of flying speed, atmospheric conditions or rolling terrain.
4. The best speed for take-off is at about 80 MPH under normal conditions. Trying to pull the airplane off the ground at too low an airspeed decreases the controllability of the airplane in event of engine failure. (Minimum controllable single engine airspeed is 80 MPH.)
5. Do not use fuel crossfeed to compensate for an inoperative emergency fuel pump.
6. In high density areas where high traffic pattern speeds are necessary or when it is advantageous to extend the gear, it is permissible to extend the landing gear at speeds up to 150 MPH; however, it is recommended the landing gear should normally be extended at speeds below 150 MPH.
7. Flaps may be lowered at speeds shown in the A.F.M. Slower speeds are desirable to help reduce flap operating loads.
8. Before attempting to reset any circuit breaker, allow a two to five minute cooling off period.
9. Always determine position of landing gear by checking the gear position lights and the mirror on the right side of the left cowl.
10. To prevent tripping the overheat lockout switch and to get best service life from the heater components, it is recommended that the heater switch be turned to "FAN" just prior to landing. This will allow adequate cooling during ground operation.
11. Remember that when the post lights are on, the gear position lights are dimmed.
12. Before starting the engines, check that all radio switches, light switches, and the pitot heat switch are in an off position so as not to create an overloaded condition when the starter is engaged.
13. The trim tab on the Aztec is very responsive and a small adjustment in trim control gives a rapid trim change attitude.
14. When flying in icing conditions the engine ram air filter can flash over with impact ice. The alternate air door will open and a manifold pressure change may occur.
15. A high fuel pressure indication on the fuel flow indicator is a possible indication of restricted air bleed nozzles.
16. Pilots who fly above 10,000 feet should be aware of the need for special physiological training. Appropriate training is available at approximately twenty-three Air Force Bases throughout the United States for a small fee. The training is free at the NASA Center in Houston and at the FAA Aeronautical Center in Oklahoma.

Forms to be completed (Physiological Training Application and Agreement) for application for the training course may be obtained by writing to the following address:

Chief of Physiological Training AAC-143  
 FAA Aeronautical Center  
 P. O. Box 25082  
 Oklahoma City, Oklahoma 73125

It is recommended that all pilots who plan to fly above 10,000 feet take this training before flying this high and then take refresher training every two or three years.

## OPERATING TIPS

REVISED: February 23, 1976

PAGE 1

17. In an effort to avoid accidents, pilots should obtain and study the safety related information made available in FAA publications such as regulations, advisory circulars, Aviation News, AIM and safety aids.

18. The shape of the wing fuel tanks is such that in certain maneuvers the fuel may move away from the tank outlet. If the outlet is uncovered, the fuel flow will be interrupted and a temporary loss of power may result. Pilots can prevent inadvertent uncovering of the outlet by having adequate fuel in the tank selected and avoiding maneuvers which could result in uncovering the outlet.

Unbaffled Tanks (Ser. Nos. 27-4426, 27-4574 through 27-7405476):

Normal takeoffs are not to be made when the tank selected is less than one-quarter full.

Running turning takeoffs should be avoided as fuel flow interruption may occur when the tank selected is less than half full.

Prolonged slips or skids of 30 seconds or more, in any pitch attitude or other unusual or abrupt maneuvers which could cause uncovering of the fuel outlet must be avoided when the tank selected is less than half full.

Baffled Tanks (Ser. Nos. 7554001 and up)

Normal and running turning takeoffs are not to be made when tank selected is less than one-quarter full as fuel flow interruption may occur.

Prolonged slips or skids of 30 seconds or more, in any pitch attitude or other unusual or abrupt maneuvers which could cause uncovering of the fuel outlet must be avoided when the tank selected is less than one-quarter full.

19. If a single-engine landing is necessary, a check should be performed to determine whether or not the hydraulic pump is functioning for normal gear extension. This check is accomplished by placing the landing gear selector in the "UP" position with the gear retracted. If the hydraulic pump is functioning, pressure will return the control to the neutral position. This check should be performed before entering the traffic pattern so that there will be sufficient time to extend the gear by use of the hand pump or, if necessary, by use of the emergency CO<sub>2</sub> gear extension system.

20. Experience has shown that the training advantage gained by pulling a mixture control or turning off the fuel to simulate engine failure at low altitude is not worth the risk assumed. Therefore, it is recommended that instead of using either of these procedures to simulate loss of power at low altitude the throttle be retarded slowly to idle position. Fast reduction of power may be harmful to the engine.

# OPERATING INSTRUCTIONS

# OPERATING INSTRUCTIONS

**THIS SECTION IS DESIGNED:**

1. To help you operate your Aztec "E" with safety and confidence.
2. To more fully acquaint you with the basic performance and handling characteristics of the airplane.
3. To more fully explain your Aztec "E's" operation than is permissible to set forth in the Airplane Flight Manual.

Preflight . . . . .	1
Before Starting Engines . . . . .	2
Starting Engines . . . . .	2
Pre Taxi and Taxi . . . . .	3
Warm-Up and Ground Check . . . . .	3
Pretake-Off . . . . .	4
Take-Off and Climb . . . . .	5
Spins . . . . .	6
Cruising . . . . .	6
Leaning Procedures . . . . .	6
Propeller Synchronizer Operating Procedures . . . . .	8
→ Propeller Synchrophaser . . . . .	9
Approach and Landing . . . . .	9
Post Landing . . . . .	11
Weight and Balance . . . . .	11
Alternate Induction Air . . . . .	11
Rough Air Flight . . . . .	12
Radio Operation . . . . .	12
→ Piper Automatic Locator . . . . .	12

## OPERATING INSTRUCTIONS

## PREFLIGHT

The following safety procedure instructions must become an integral part of the pilot's operational routine and preflight inspection.

Begin the preflight inspection in the cockpit. Check that the landing gear selector is in the neutral position. Turn master switch on and check that the green landing gear indicator lights are on. If the green lights are not on, make sure that the instrument panel light switch is turned to the OFF position. The landing gear indicator lights are automatically dimmed and difficult to see in the daytime if the instrument lights are on.

During the external preflight check see that the baggage doors are properly secured. Prior to flight, passengers should be briefed about seat belts, the use of oxygen when applicable, how to evacuate the airplane, and advised not to smoke during take-off or landing. They should be cautioned against handling or interfering with essential equipment and flight controls, fuel valves, switches, circuit breakers, trim knob or cranks, door handle, radios, etc.

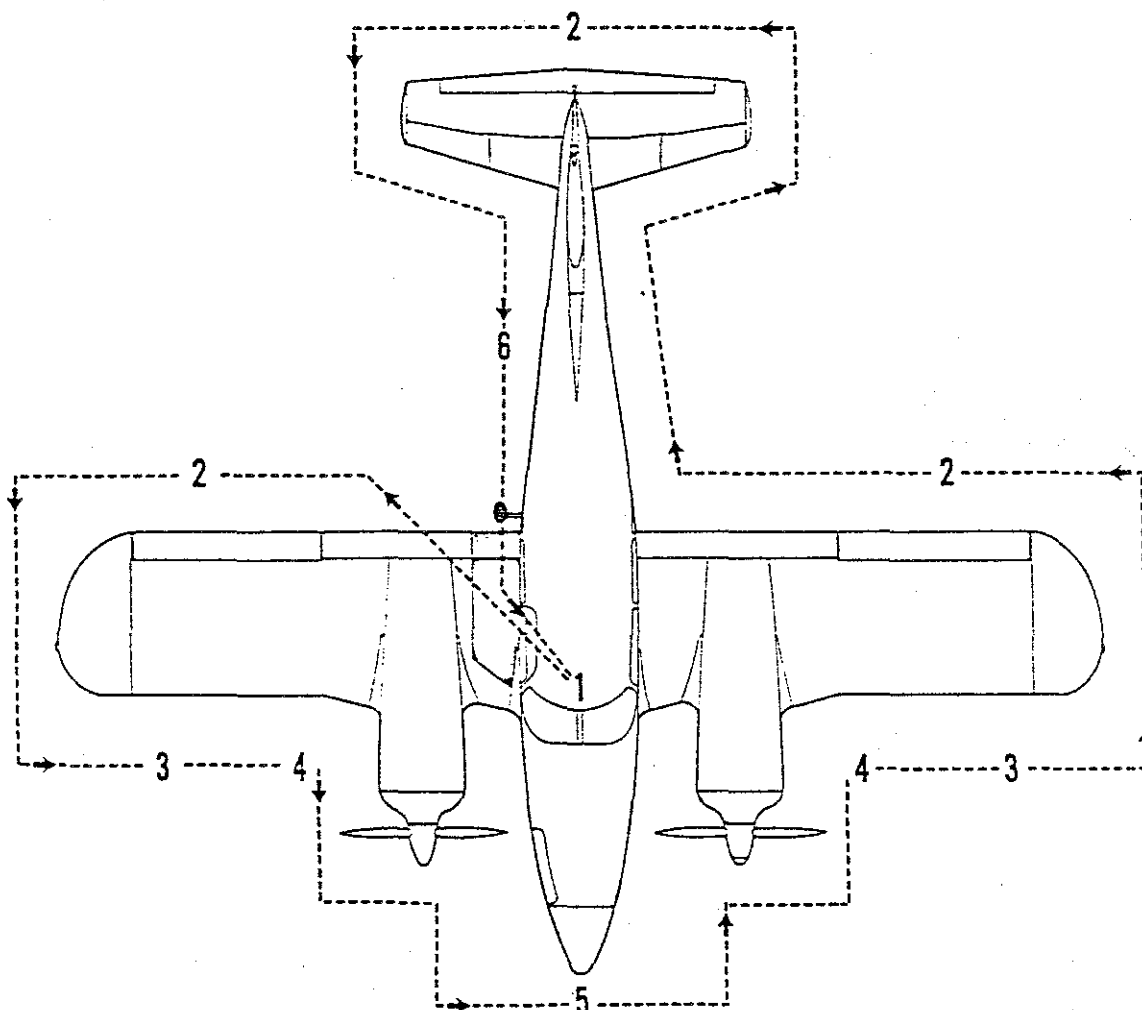

## AZTEC "E"

---

1. a. Ignition and master switches "OFF".  
b. Check that the landing gear selector and the other controls are in their proper position.
2. a. Check for external damage or operational interference to the control surfaces, wings or fuselage.  
b. Check for snow, ice or frost on the wings or control surfaces.
3. a. Visually check fuel supply.  
b. Check fuel cell caps and covers for security (adjust caps to maintain tight seal).  
c. Fuel system vents open.
4. a. Landing gear shock struts properly inflated (approximately 3" piston exposed).  
b. Tires satisfactorily inflated and not excessively worn.  
c. Drain fuel strainers and lines.  
d. Cowling, landing gear doors and inspection covers properly attached and secured.  
e. Propellers free of detrimental nicks.  
f. No obvious fuel or oil leaks.  
g. Engine oil at the proper level.
5. a. Windshield clean and free of defects.  
b. Tow-bar and control locks detached and properly stowed. Check that baggage doors are secured.
6. a. Upon entering the airplane check that all controls operate normally.  
b. Check that the landing gear selector and the other controls are in their proper position.  
c. Check that required papers are in order and in the airplane.

### BEFORE STARTING ENGINES

1. Baggage - secure.
2. Weight and C.G. - compute.
3. Performance - compute.
4. Aircraft papers - in order *License crew*
5. Maps and charts - check.
6. Cabin door - locked.
7. Seat belts - secure.
8. Crew seats - adjusted.
9. Parking brake - set.
10. Altimeter - set.
11. Controls - response.
12. ~~Oxygen press~~ - check for adequate supply.
13. Fuel valves - on.
14. Circuit breakers - check.
15. Switches (Radio, etc.) - off.  
Except: Main voltage regulator - on.  
Alternators - on.

*Passenger Briefing*

### STARTING ENGINES

Be sure that all radio switches, light switches and pitot heat switch are in the off position before starting engines. *1*

1. Master switch - on.
2. Cowl flaps - open to proper position.



3. Throttle controls - open 1/2 inch.
4. Propeller controls - forward.
5. Electric fuel pumps - on.
6. Mixture controls - rich until indication on fuel flow gauge, then idle cut-off.
7. Magneto switches - on.
8. Propellers - clear.
9. Starters - engage.
10. Mixtures - advance.
11. Oil pressure - check.

If engine does not fire within 5-10 seconds, disengage starter and reprime.

#### Starting Engine When Hot:

1. Master switch - "ON".
2. Magneto switches - "ON".
3. Electric fuel pump - "OFF".
4. Open throttle 1/2 inch.
5. Mixture in idle cut-off.
6. Engage starter.
7. Mixture full rich when engine fires.
8. Check oil pressure.

#### Starting Engine When Flooded:

1. Master switch - "ON".
2. Magneto switches - "ON".
3. Electric fuel pump - "OFF".
4. Throttle full open.
5. Mixture in idle cut-off.
6. Engage starter.
7. Retard throttle and advance mixture when engine fires.
8. Check oil pressure.

Cranking periods should be limited to 30 seconds with a two minute interval between. Longer cranking periods shorten the life of the starter.

#### PRE TAXI AND TAXI

1. Radio - as required.
2. Parking brake - off.
3. Brake operation - check.
4. Lights - as required.
5. Flight instruments - operating.
6. Emergency locator - check.

#### WARM-UP AND GROUND CHECK

Check the oil pressure as soon as the engines start. If no pressure is indicated within thirty seconds stop the engine and determine the trouble. If cold temperatures exist (10° F or below), a longer period of time will be necessary before an indication is received.

#### OPERATING INSTRUCTIONS

ISSUED: September 1, 1970

REVISED: December 10, 1971

Warm-up the engines at 1000 to 1400 RPM for not more than two minutes in warm weather and four minutes in cold. The engines are warm enough for take-off when no faltering occurs with the throttle opened. Avoid prolonged idling at low RPM to prevent fouled spark plugs. Check the magnetos with the propeller in low pitch (max. RPM) and the engine running at 2200 RPM. The maximum drop on each magneto should not exceed 175 RPM and the differential drop between magnetos should not exceed 50 RPM. Operation on one magneto should not exceed 10 seconds. The engines are warm enough for takeoff when the throttle can be opened without engine faltering.

NOTE

On turbocharged airplanes, engine oil temperature gauge reading must be above 60° before full power is applied.

Move the propeller controls through their complete range to check feathering action, then leave them in the full forward low pitch position. Feathering action can be checked by running the engine between 2000 and 2200 RPM and pulling the prop control rapidly in and out of feathered position to prevent a drop of more than 500 RPM. Excessive manifold pressure will occur if the RPM falls below 1000 during this check. Propellers should be cycled three times in cold weather.

Cowl flaps permit cooling of the engines by manual control during ground operations or special conditions of flight. It is recommended that cylinder head temperature not exceed 435° F and the oil temperature should not exceed 245° F.

The electric fuel pumps should be turned off after starting or during warm-up to make sure that the engine driven pumps are operating. Prior to take-off the electric pumps should be turned on again to prevent loss of power during take-off should an engine driven pump fail.

To check that the engine-driven hydraulic pump is functioning, place the landing gear selector in the "DOWN" position with the gear down and the left engine running. The gear selector will automatically return to the neutral position if the hydraulic pump is producing pressure.

PRE TAKE-OFF

The autopilot should be off before take-off.

On a cold day, test defroster and cabin heater before take-off. Do not fly in cold weather when the heater is inoperative, as the windshield may become frosted.

Check list:

1. Parking brake - on.
2. Engine run-up.
  - (a) Mixture controls - forward.
  - (b) Propeller controls - forward.
  - (c) Throttle controls - forward (2200 RPM) × *mixture lean to peak*
  - (d) Magnetos - check.  
Maximum drop - 175 RPM  
Maximum differential drop left to right - 50 RPM.
  - (e) Throttle controls - forward (2200 RPM).
  - (f) Propeller controls - exercise.  
(Check feather, 500 RPM maximum decrease.)
3. Engine gauges - check green.
4. Lights - as required.
5. ~~Pitot heat~~ - as required.
6. Transponder - stand-by.

7. Trim tabs - set.
8. Gyro pressure - 4.8 to 5.1 in. Hg.
9. Directional Gyro - set.
10. Turn and Bank - operating.
11. Altimeter - set.
12. Clock - wind and set.
13. Alternator output - check.
14. Electric fuel pumps - on.
15. Door - locked.

16. Crew briefing.

MAP "TERMINAL, Return, Review Clearance."

The normally recommended setting for sea level take-off is full throttle at 2575 RPM. The slightly rich mixture for this setting aids in cooling the engine.

#### TAKE-OFF AND CLIMB

When Ready To T/O  
Transponder,  
Pitot heat  
strobe & lights  
2G check

CAUTION

Do not take-off with ice or frost on the wings, as ice or frost will radically change the flight characteristics of the airplane.

1. Parking brake - off.
2. Mixture controls - forward.
3. Propeller controls - forward.
4. Throttle controls - forward.
5. Accelerate to - 80 MPH (69 knots)  
(Prior to climb)
6. Landing gear - retract.
7. Accelerate to - best R/C speed.
8. Climb power - set.  
(At approx. 400 AGL)
9. Electric fuel pump - off one at a time.
10. Cowl flaps - set.  
(Maintain cylinder head temperature at or below maximum.)
11. Oxygen - on.  
(Above 10,000' or lower, as required.)

Trim for take-off so that a light back pressure on the control wheel allows the airplane to lift from the runway.

On take-off the aircraft should be kept either on, or near the runway, until reaching  $V_{mc}$ . After  $V_{mc}$  has been reached the aircraft should be accelerated as rapidly as possible to the best rate of climb speed if there are no obstacles ahead. If there are obstacles ahead maintain the best angle of climb speed. The applicable speed should be maintained until all obstacles are cleared and the airplane gains sufficient altitude.

During normal conditions, retraction of the landing gear should occur when a gear down landing is no longer possible on the runway. Attain the best rate of climb speed and at least 400 feet above ground level before reducing power.

The best rate of climb is obtained initially at 120 MPH (104 knots) on normally aspirated airplanes and 115 MPH on turbocharged airplane, but to give a high forward speed as well as a good rate of climb, a cruising climb speed of 135 MPH (117 knots) is recommended. Turn the electric fuel pump off after climb out.

On airplanes equipped with 24 volt 70 amp alternators, the cowl flaps must be full open during climbs above 18,000 ft with an alternator load of 60 amps or more.

## SPINS

All spins are prohibited, however in the event an unintentional spin is encountered recovery can be accomplished by immediately using the following procedures:

- a. Retard both throttles to the idle position.
- b. Apply full rudder in the opposite direction to the spin.
- c. Push control wheel full forward. While it is not necessary for recovery, the use of ailerons against the turn (i.e. right aileron if spin is to the left) will expedite recovery.
- d. Maintain controls in these positions until the spin stops. Then neutralize rudder and ailerons.
- e. Recover from dive with smooth back pressure on the control wheel. No abrupt control movement should be used during recovery from the dive, as the maneuvering speed and positive limit maneuvering load factor may be exceeded.

## CRUISING

1. Electric fuel pumps - off.
2. Power - set.
3. Mixture - lean in accordance with instructions below.
4. Cowl flaps - set.  
(Position to maintain allowable cylinder head and oil temperatures.)
5. Fuel valves - on.
6. Trim - set.
7. Engine gauges - check and monitor.

The cruise power concept now possible with Lycoming engines permits more efficient use of the available horsepower. Simplified power management allows a more constant manifold pressure and eliminates continual reference to power charts.

Refer to Power and Performance charts for power settings.

To INCREASE power, first increase RPM; then increase manifold pressure.

To DECREASE power, first decrease manifold pressure; then decrease RPM.

To obtain the desired cruise, set the manifold pressure and RPM according to the power setting table.

During climbing operation the servo regulator will sense the change in altitude and will automatically lean the mixture. For better economy, manual leaning with the mixture control can be accomplished. For information on leaning procedure see Avco-Lycoming approved Leaning Procedures for Aztec "E" engines.

Since a fuel injected engine such as is used on the Aztec takes an appreciable length of time to start after fuel starvation, it is recommended that you avoid emptying a fuel cell to depletion. If it is necessary to use all the fuel in a fuel cell, carefully monitor the fuel flow meter and change the fuel selector valve position at the first indication of a decrease in fuel flow. This will enable you to keep the engine operating while using all of the fuel in the fuel cell.

## LYCOMING APPROVED LEANING PROCEDURES FOR AZTEC "E" ENGINES

### BASIC LEANING INFORMATION.

- A. At 75% power or less the engine may be leaned anywhere as desired and at any altitude as long as the engine operates smoothly, and the temperatures and pressures are within prescribed limits.
- B. Use of more than 75% power with improper leaning can result in engine damage. When in doubt use full rich mixture above 75% power, otherwise carefully follow these steps for correct cruise leaning:
  1. Establish 75% cruise power and lean to peak EGT without exceeding 1650° F on EGT.
  2. Reduce temperature 125° F below peak EGT by enriching at 75% power and mark this position on the EGT gauge.
  3. Return the mixture control to the rich position and increase RPM and MP to desired higher power.

4. Lean out mixture until EGT is at value established in step 2 above. Monitor cylinder head temperature. Cross check fuel flow. Do not lean to peak EGT above 75% power.
- C. Take-off and climb below 5,000 feet, use full rich mixture through 5,000 feet with an unturbocharged engine; for continued climb lean mixture for smooth engine operation only, not for economy.

#### Normally Aspirated Fuel Injected Power Plants:

Observe fuel flow gauge as a general reference for leaning, use the exhaust gas temperature gauge for specific leaning reference, cross check cylinder head temperature gauge. If these instruments are not available, limit power for cruise to 75% and lean until engine roughens or loses power, then enrich for smooth operation.

#### BASIC LEANING INFORMATION. (Turbocharged Power Plant)

For turbo cruise, intermediate, economy and long range cruise (best economy) select desired RPM and MP then adjust the mixture to obtain and operate at peak EGT.

For best power - carefully follow steps listed below:

1. Select desired RPM and MP.
2. Adjust the fuel mixture to obtain peak EGT.
3. Increase fuel mixture and lower EGT value 125° F from established peak value.

#### CAUTION

Never exceed 1650° F EGT whenever determining peak.

4. If reaching 1650° F before obtaining peak EGT, it will be necessary to reduce MP to a lower cruise power setting before again attempting to determine peak EGT.
5. When peak EGT has been established at the reduced power setting, return mixture control to full rich before adjusting throttle to increase MP to turbo-cruise conditions.
6. Adjust and lean mixture to EGT value of 125° F from the peak value obtained in step 4.

#### NOTES

1. Always return mixture to full rich before changing power settings.
2. Never permit exhaust gas temperature to exceed 1650° F.
3. For maximum service life, maintain cylinder head temperature below 435° F during high performance cruise operation and below 400° F for economy cruise powers.

#### RELATED GENERAL INFORMATION

- A. If cylinder head temperatures are higher than recommended during flight, reduce them to within recommended operating range by enriching the mixture, or by adjusting cowl flaps, or by reducing power, or by the use of any combination of these methods.
- B. In general the left and right engine cylinder head temperatures should be essentially the same with equal leaning at equal powers.
- C. Definitions:
  1. Best power mixture - the leanest mixture strength which produces the highest indicated airspeed for any given engine speed and manifold pressure.
  2. Best economy range mixture - leaned to peak EGT or approximately 10° F to the lean side of peak. On those engines without an EGT, it is the leanest mixture position without roughness and with a slight loss in cruise airspeed.

During flight, keep account of time and fuel used in connection with power settings to determine how the fuel flow and fuel quantity gauging systems are operating. If the fuel flow indication is considerably higher than the fuel actually being consumed or an asymmetric flow gauge indication is observed, you may have a clogged fuel nozzle which should be cleaned.

#### PROPELLER SYNCHRONIZER OPERATING PROCEDURES (With Manual Phase Control)

The propeller synchronizer is a electro-mechanical servo mechanism that will maintain the speed of the "slaved" propeller coincident with the speed of the "master" propeller. The left engine is set up as the "master" and the right engine as the "slave". The control is a concentric control with the outer knob as mode selector and the inner knob for phase control.

**For Taxiing:**

Set the synchronizer switch to "MAN".

**For Take-off:**

After advancing throttles and tightening the control pedestal friction knob, set the synchronizer switch to "AUTO".

**For Cruise:**

Set the synchronizer switch to "MAN". Establish the desired power setting; manually synchronizing the props to within 5 R.P.M. Tighten friction knob and set synchronizer switch to "AUTO".

**Phase Control:**

The center knob of the concentric control is for phase control. It will vary the relative blade positions of the two propellers, up to 180°, to reduce the acoustic input to the fuselage.

Select the position of the phase control for best pilot and/or passenger comfort. Make change in small increments and allow 20 seconds at each setting for the propellers to stabilize.

#### PROPELLER SYNCHROPHASER OPERATING PROCEDURE

The propeller synchrophaser automatically maintains both propellers at the same RPM and at a preselected phase angle. This eliminates the propeller "Beat" effect and minimizes vibration.

The left engine is established as the master engine. The right engine is equipped with a slave governor which automatically maintains its engine RPM with the left engine RPM.

The propeller synchrophaser switch is located on the lower left side of the instrument panel. It has two positions, "MAN." for manual or stand by and "Prop Sync." for propeller synchrophaser.

**For Taxiing:**

Set the synchrophaser switch to "MAN."

**For Take-off and Landing:**

Set the synchrophaser switch to "MAN."

**For Cruise:**

Synchronize the propellers as close as possible manually within approximately 10 RPM, then set the synchrophaser switch in the "Prop Sync." position.

**NOTE**

Normally, propeller synchrophasing is achieved in a few seconds but occasionally it may take a full minute to achieve full propeller synchrophasing.

If a change in power setting is desired, set the synchrophaser switch to "MAN." position, wait 30 seconds. Adjust the power setting, then set the synchrophaser switch in the "Prop Sync." position.

Propeller "Phase" is preset at the factory. For further information on Phase control and the Propeller Synchrophasing System, consult your aircraft service manual.

**NOTE**

Should it be necessary to completely deactivate the Prop Sync. system the circuit breaker must be pulled.

**NOTE**

Each time a propeller RPM differential greater than 50 RPM occurs, it will be necessary to recycle the system to "MAN." for 30 to 40 seconds. Manually re-synchronize propellers, then turn switch to "Prop Sync." position.

**NOTE**

Should there be an electrical system failure or the master switch is turned off, the slave engine will return to the controlled selected RPM + approximately 25 RPM regardless of the position of the synchrophaser switch (out of synchronization).

**APPROACH AND LANDING**

Prior to extending the landing gear for landing, retard both throttle controls to check that the landing gear warning horn is operating. Flying the airplane with the horn inoperative is not permitted. It can lead to a gear up landing as it is easy to forget the landing gear when approaching for a single engine landing when other equipment is inoperative or when attention is drawn to events outside of the cockpit. Therefore it is especially important to check that the landing gear is down when there is any distraction in the landing situation.

Lower the gear at speeds below 150 miles per hour and the flaps at speeds listed on the landing check list. The flaps extend in approximately 8 to 10 seconds and retract in approximately two seconds. Maintain sufficient speed during turns in the traffic pattern. Set the propeller at a high cruising RPM of at least 2400 RPM for ample power if a go-around is necessary. Mixture control should be in the full rich position unless density altitude or conditions of high temperature and humidity dictate otherwise.

Ascertain the landing gear is down and locked on base leg or final approach by checking the green indicator lights on the instrument panel and the external mirror to make sure the nose landing gear is extended.

**OPERATING INSTRUCTIONS**

ISSUED: September 1, 1970

REVISED: December 10, 1971

PAGE 9

## NOTE

When the instrument lights are on, the gear position lights are dimmed for night flight.

The degree of wing flap extension and touch down speed vary with conditions, but under normal conditions full wing flap (50 degrees) should be used during the final approach and landing to reduce stall speed and to permit contact with the runway at a slower speed.

Contact the ground at the minimum speed consistent with landing conditions.

For short, slow landings under normal conditions use full wing flaps, partial power, and hold the nose up as long as possible before and after contacting the ground with the main wheels.

In high winds and crosswinds, it is desirable to approach a landing at higher than normal speeds with half or no wing flaps. If a go-around is necessary apply full throttle, retract the landing gear, and slowly retract the wing flaps.

During a crosswind approach hold a crabbed angle into the wind until ready to flare out for the landing. Then lower the wing that is into the wind, reduce crabbed angle, and keep the wheels aligned to the runway using rudder.

Avoid prolonged side slip with a fuel selector set to a fuel cell with low fuel indication.

Prior to landing and early in the roll out, the brakes should be checked for operation. After landing maximum braking is achieved by retracting wing flaps and pulling back on the control wheel as wheel brakes are applied.

## CAUTION

It is possible for a pilot to inadvertently reach for the landing gear selector switch instead of the wing flap switch while there is still enough lift on the wings to keep full weight of the airplane off the wheels and thus prevent the actuation of the landing gear safety mechanism, causing retraction during the landing roll. If additional braking is not needed, the wing flaps should be retracted after the airplane has been maneuvered to a stop off the runway. If a landing must be made without wheel brakes the airplane should be flown to contact the ground at a slower speed and landed short on the longest available runway.

The procedure for manually lowering the landing gear should be memorized and understood completely so that it can be accomplished quickly in an emergency situation, such as a single engine landing. (See Emergency Procedures.)

Landing check list:

1. Oxygen (below 10,000 ft) - off.
2. Seat belts - fastened.
3. Electric fuel pumps - on.
4. Mixture controls - forward.
5. Fuel valves - on, fullest cells.
6. Landing gear (under 150 MPH) (130 knots) - extend, check green.
7. Propellers - set.
8. Cowl flaps - as required.
9. Flaps - set.



- |           |                            |
|-----------|----------------------------|
| Full Flap | 125 MPH (104 knots) (max.) |
| 1/2 Flap  | 140 MPH (122 knots) (max.) |
| 1/4 Flap  | 160 MPH (139 knots) (max.) |
10. Heater (if used) - fan on.

## POST LANDING

### Check List:

1. Wing flaps - retract.
2. Cowl flaps - open.
3. Electric fuel pump - off.
4. Prop controls - forward.

When completely stopped in a parking spot, check the following items for shut down:

1. Radio and elec. equip. - off.
2. Heater (if used) fan - off.
3. Mixture controls - idle cut-off.
4. Magneto switches - off.
5. Master switch - off.
6. Parking brake - on.
7. Main volt reg. - on.
8. ~~Alternators - on.~~

If control locks are not available and the airplane is to be left for more than a few minutes, secure the control wheel with the safety belt strap. Chock the wheels and secure tie downs at appropriate places.

## WEIGHT AND BALANCE

It is the responsibility of the owner and pilot to determine that the airplane remains within the allowable weight vs. center of gravity envelope while in flight. For weight and balance data, see the Airplane Flight Manual and Weight and Balance form supplied with each airplane.

In anticipation of gust load conditions when operating near zero fuel gross weight, carry fuel in the outboard tanks and distribute cargo in accordance with the Flight Manual and Weight and Balance form. Regarding increased payloads, cargo weight is not approved in excess of passenger and seat weight displaced.

## ALTERNATE INDUCTION AIR

When flying in wet, heavy snow or other conditions where the induction air filters may become clogged, monitor the manifold pressure gauge. A decrease in manifold pressure may indicate a clogged filter. If the decrease is followed by a slight increase in manifold pressure, this will then indicate that the automatic alternate induction air system is in operation, and the manifold pressure may then be brought back to the desired level with the throttle control.

A continued drop in manifold pressure would indicate that the automatic induction air system was not working. In this case, actuate the manual alternate air control, which serves as a backup for the automatic system. A partial regain of manifold pressure will indicate that the manual alternate air induction system is operating. Throttle controls may be advanced to gain additional manifold pressure.

## OPERATING INSTRUCTIONS

ISSUED: September 1, 1970

REVISED: December 10, 1971

The manual alternate air control should not be actuated on the ground with the engines operating, because the engines would then be supplied with unfiltered air. These manual controls should be placed in the FULL "ON" position prior to entering known or expected icing conditions.

### ROUGH AIR FLIGHT

In conditions of extreme turbulence, reduce power to slow the airplane below the design maneuvering speed of 149 miles per hour.

A further reduction of power will ease the stress to which the airplane is subjected by virtue of turbulence. When flying in extreme turbulence or strong vertical currents, using the autopilot, the altitude-hold mode should not be used.

### RADIO OPERATION

Communication and navigational equipment controls are located in the center of the instrument panel. Associated switches are located in a junction box above the radio stack. Circuit breakers for the radios are located on the lower right sub-panel. All sets are turned on by the switch in the control head of each unit. After power is supplied, either one of the transmitters may be operated by moving the selector switch to the desired position. Refer to individual radio operating manuals for detailed instructions.

### PIPER AUTOMATIC LOCATOR

The Piper Automatic Locator, when installed is located under the removable dorsal fin and is provided as an emergency locator signal transmitter which meets the requirements of FAR 91.52. The unit operates on a self-contained battery.

A battery replacement date is marked on the transmitter label. To comply with FAA regulations, the battery must be replaced on or before this date. The battery must be replaced if the transmitter has been used in an emergency situation or if accumulated test time exceeds one hour or if the unit has been inadvertently activated for an undetermined time period.

The unit has a three position selector switch placarded "OFF," "ARM" and "ON." The "ARM" position is provided to set the unit to the automatic position so that it will transmit only after impact and continue to transmit until the battery power is drained to depletion or the switch is manually moved to the "OFF" position. The "ARM" position is selected when the locator is installed at the factory and should remain in that position whenever the unit is installed in the aircraft. The "ON" position is provided so the unit can be used as a portable transmitter or in the event the automatic feature was not triggered by impact or to check the function of the transmitter periodically.

The "OFF" position is provided for the purpose of changing the battery or to prolong the service life of the battery if used as a portable transmitter or rearming the unit if it should be activated for any reason.

Attached to the unit is a portable antenna, provided so that the locator may be removed from the aircraft, in case of an emergency, and used as a portable signal transmitter.

The locator should be checked during the Ground Check to make certain the unit has not been accidentally activated. Check by tuning a radio receiver to 121.5 MHz. If you hear an oscillating audio sound the locator may have been activated and should be turned off immediately. Reset to "ARM" position and check again to insure against outside interference.

# PERFORMANCE CHARTS

# PERFORMANCE CHARTS

Altitude Conversion Chart . . . . .	1
Takeoff Distance Over 50 Ft. Obstacle . . . . .	2
Turbo Takeoff Distance Over 50 Ft. Obstacle . . . . .	3
Accelerate - Stop Distance . . . . .	4
Turbo Accelerate - Stop Distance . . . . .	5
Multi-Engine Rate of Climb and Airspeed vs Density Altitude . . . . .	6
Turbo Multi-Engine Rate of Climb and Airspeed vs Density Altitude . . . . .	7
Single-Engine Rate of Climb and Airspeed vs Density Altitude . . . . .	8
Turbo Single-Engine Rate of Climb and Airspeed vs Density Altitude . . . . .	9
Range vs Density Altitude . . . . .	10
Turbo Range vs Density Altitude . . . . .	11
True Airspeed vs Density Altitude . . . . .	12
Turbo True Airspeed vs Density Altitude . . . . .	13
Stall Speed vs Weight . . . . .	14
Stall Speed vs Angle of Bank . . . . .	15
Landing Distance Over 50 Ft. . . . .	16
Maximum Manifold Pressure vs Altitude . . . . .	17
Part Throttle Fuel Consumption . . . . .	18
Turbo Part Throttle Fuel Consumption . . . . .	19
Airspeed Calibration . . . . .	20
Power Setting Table (Normal Aspirated) . . . . .	21
Power Setting Table (Turbo Charged) . . . . .	21

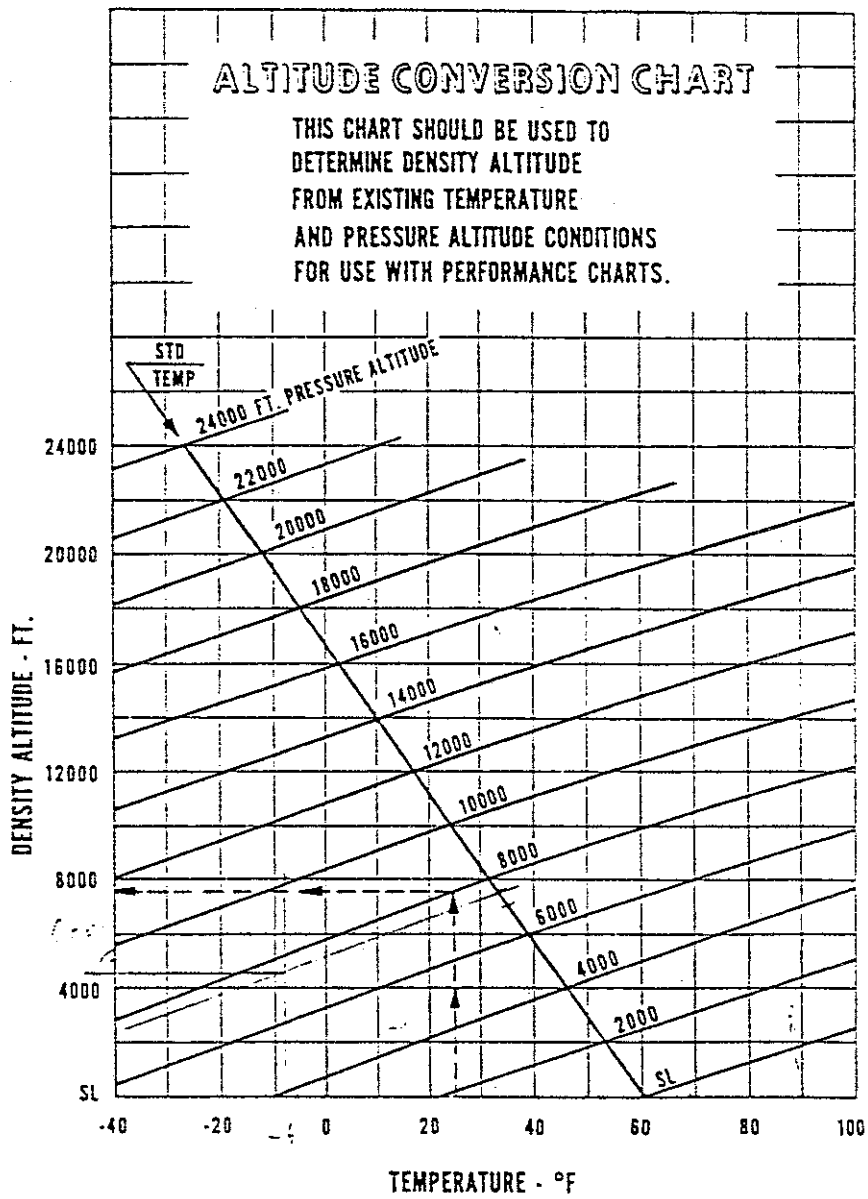

PERFORMANCE CHARTS  
ISSUED: September 1, 1970  
REVISED: October 30, 1972

# AZTEC E

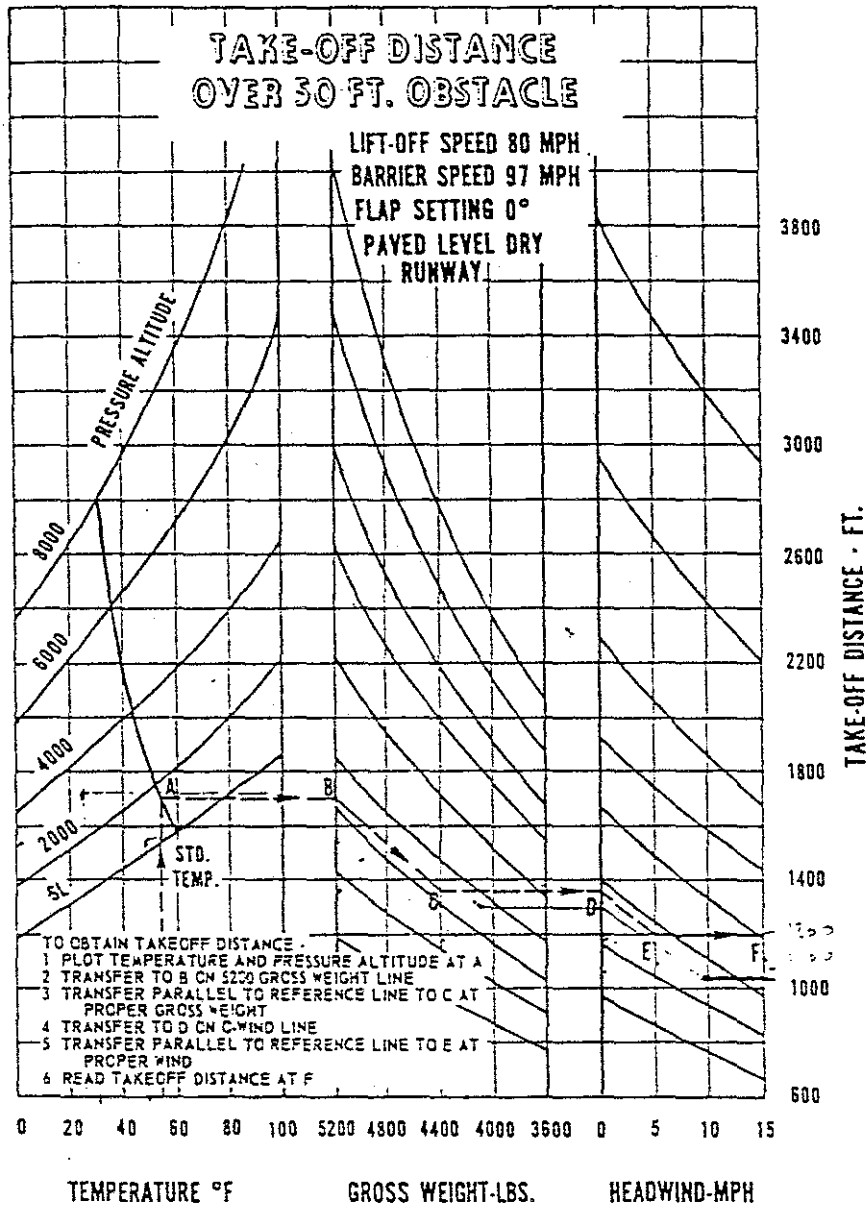

# TURBO AZTEC E

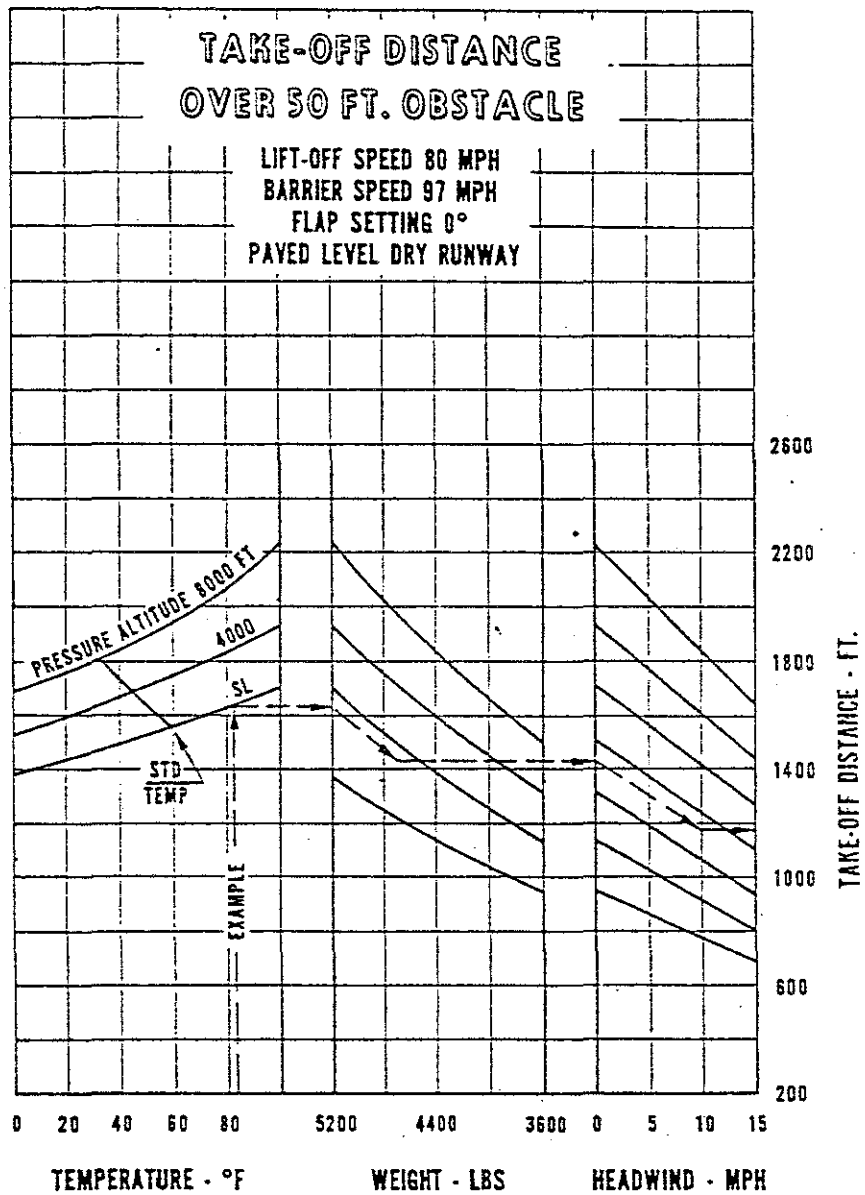

# AZTEC E

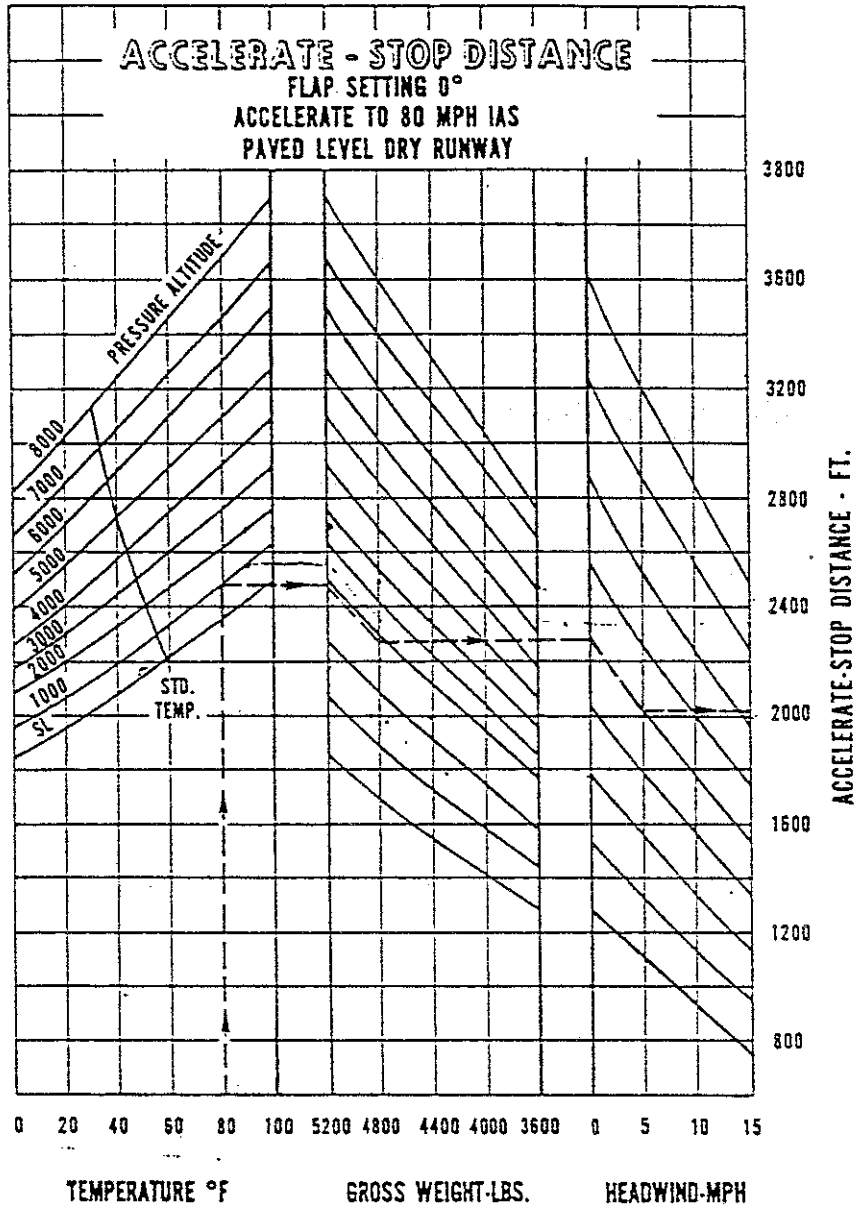



# TURBO AZTEC E

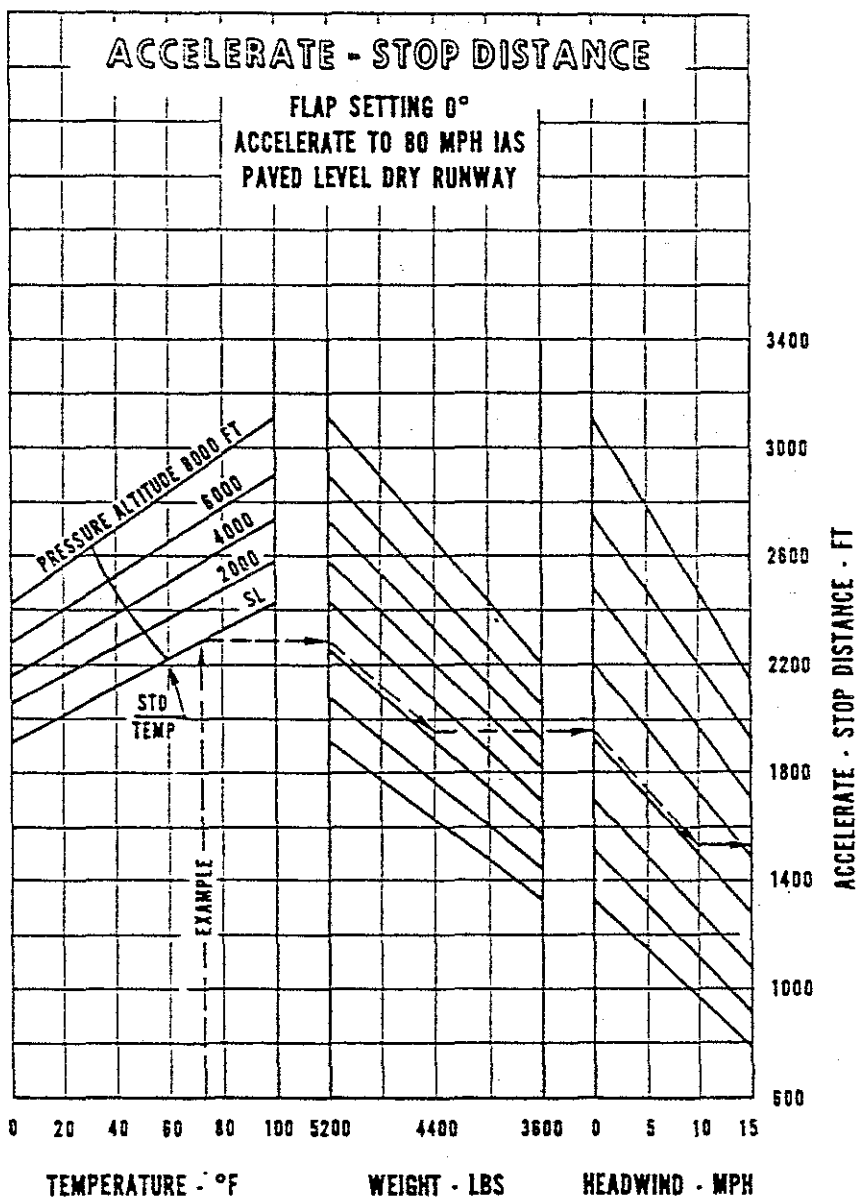

# AZTEC E

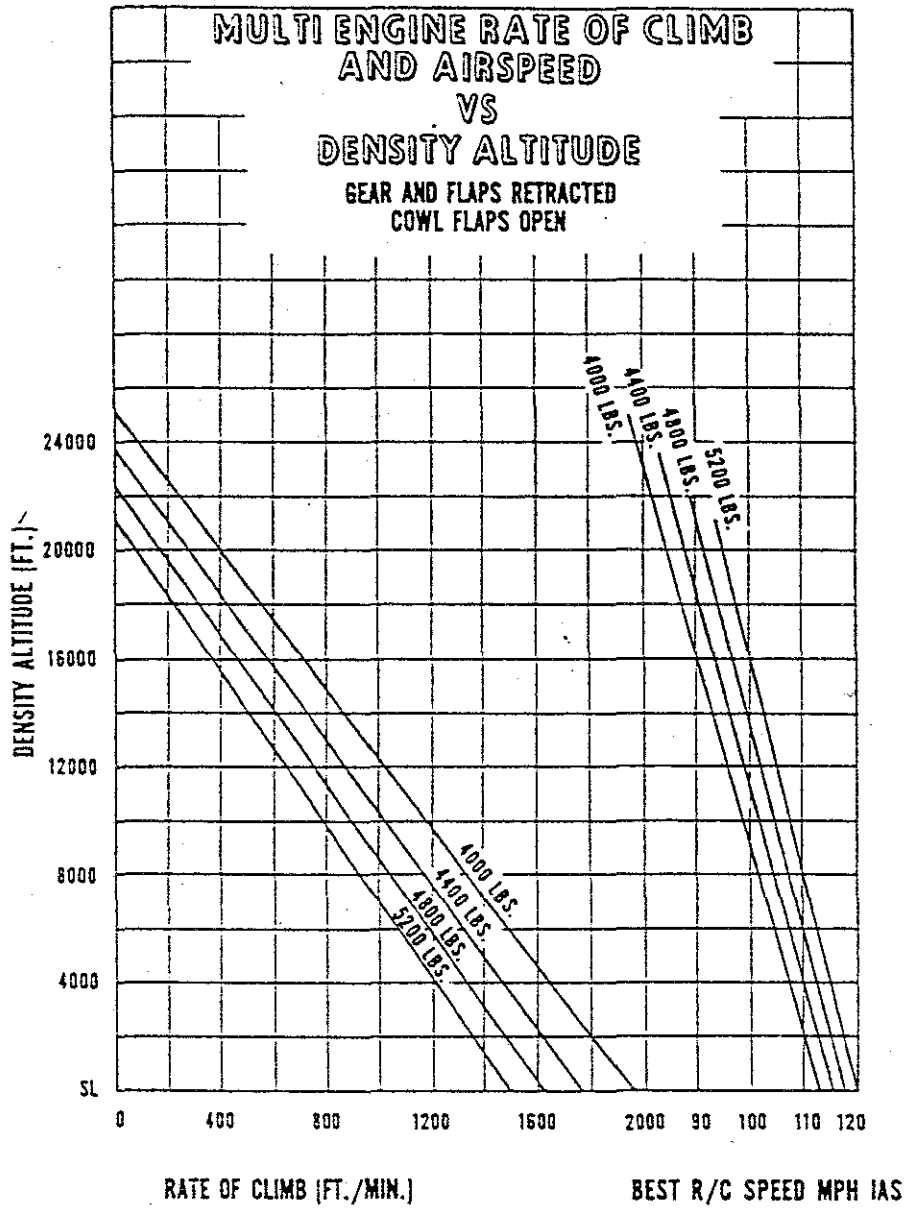

# TURBO AZTEC E

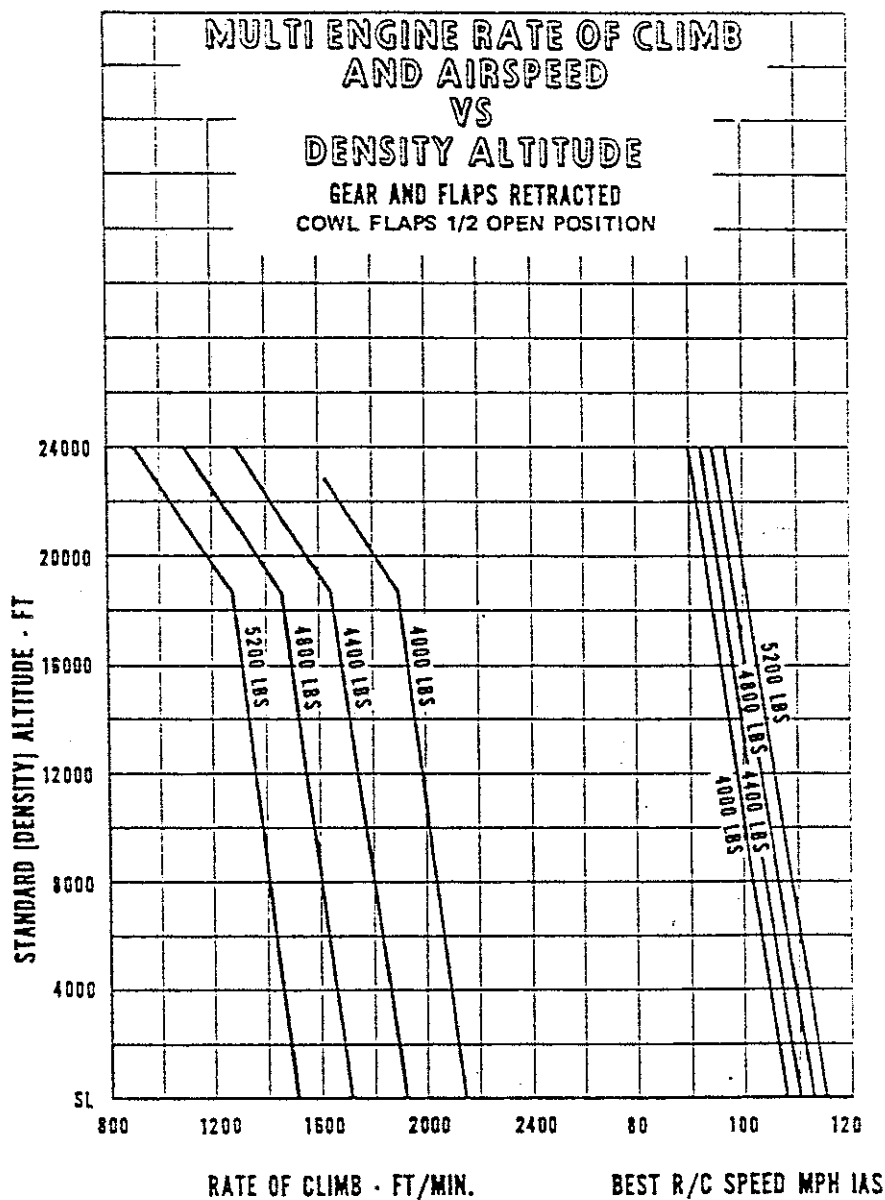

# AZTEC E

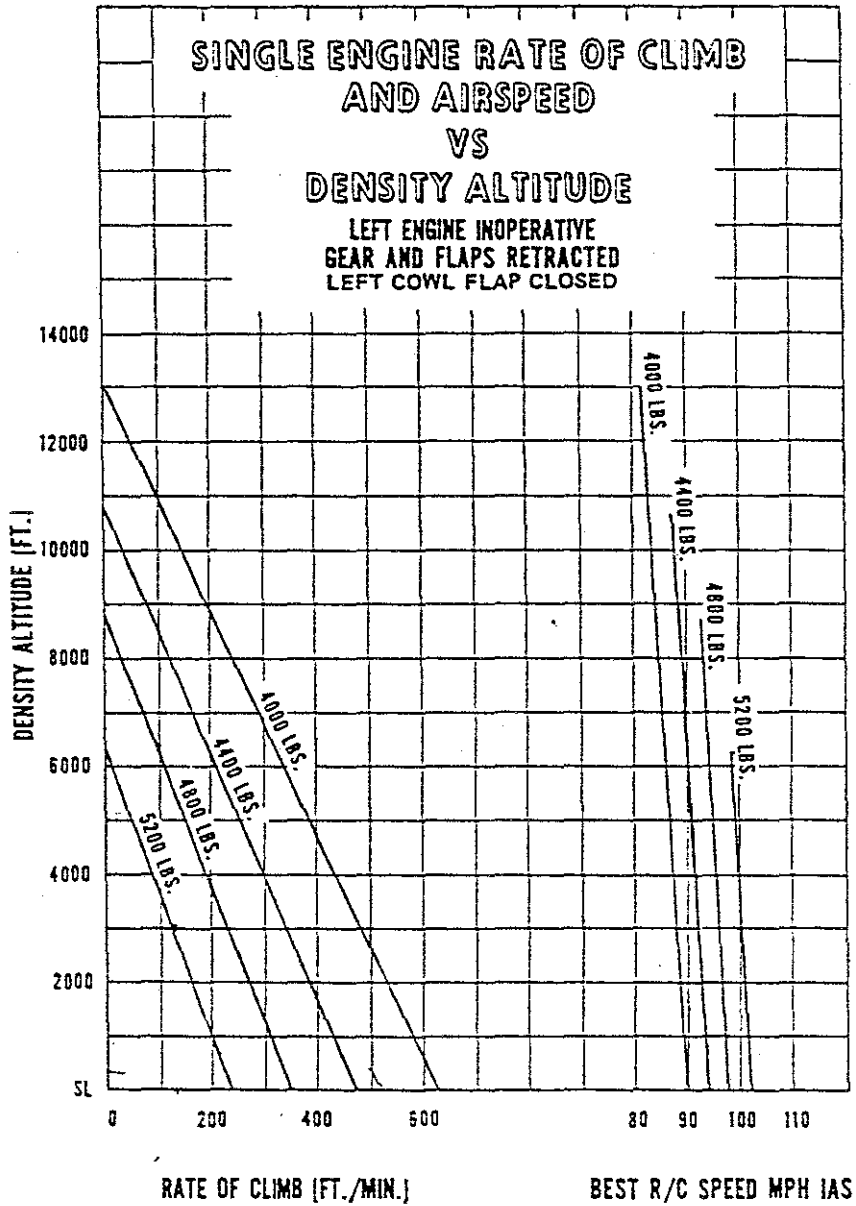

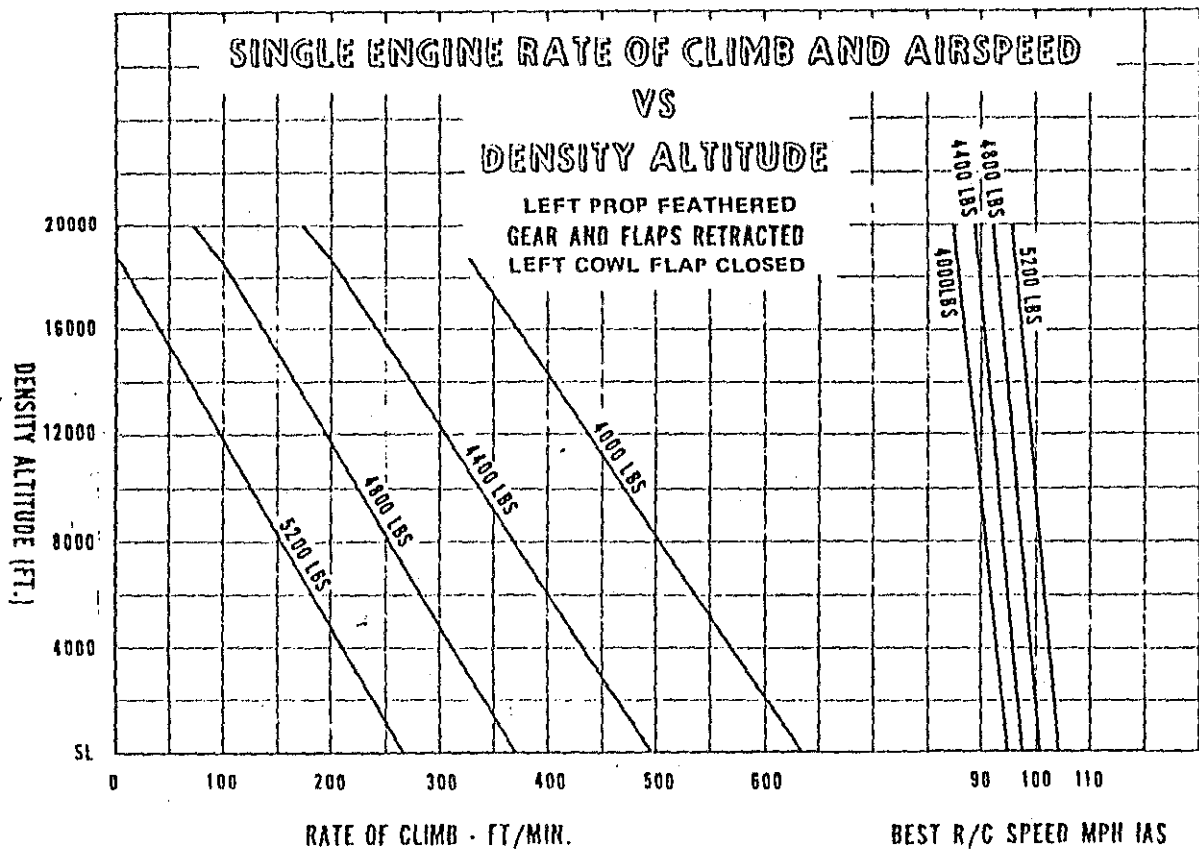

# TURBO AZTEC E

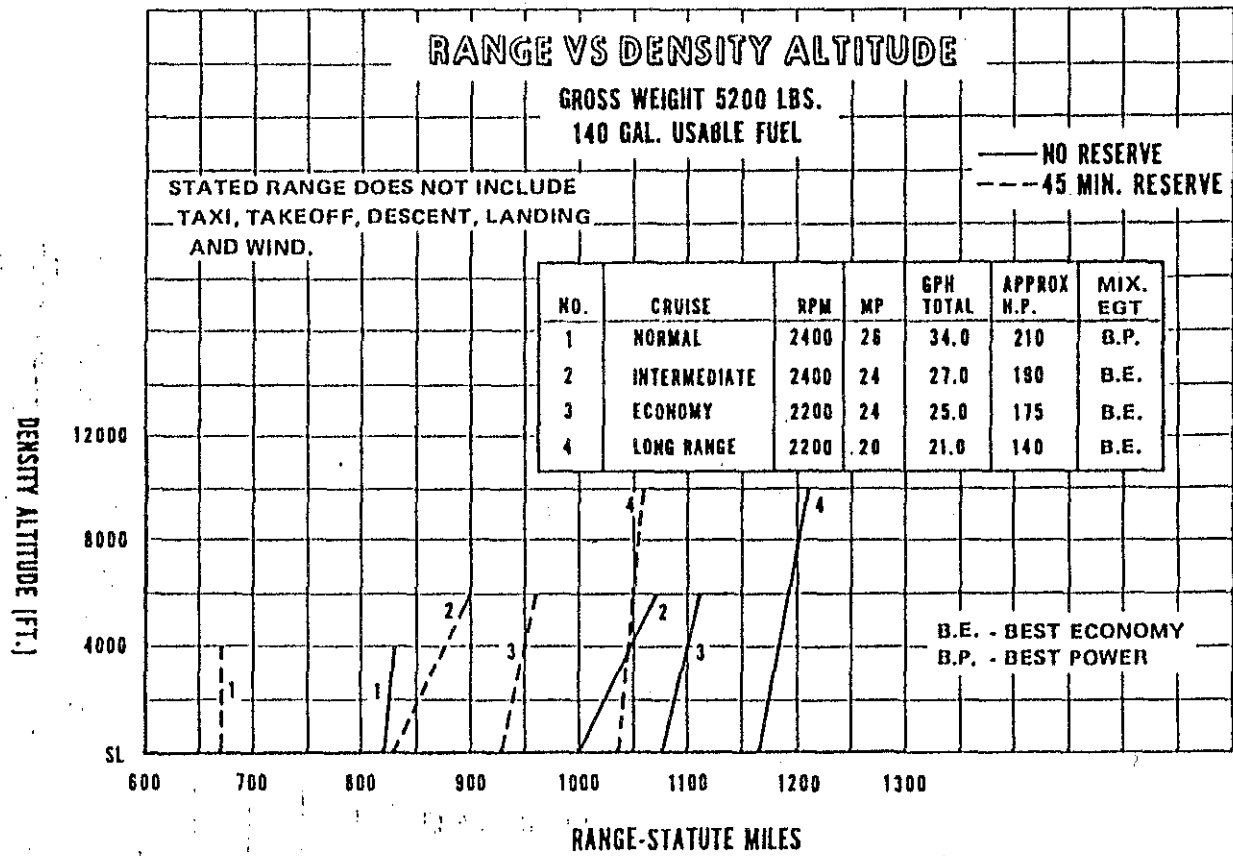

AZTEC E

PERFORMANCE CHARTS  
REVISED: October 1, 1974

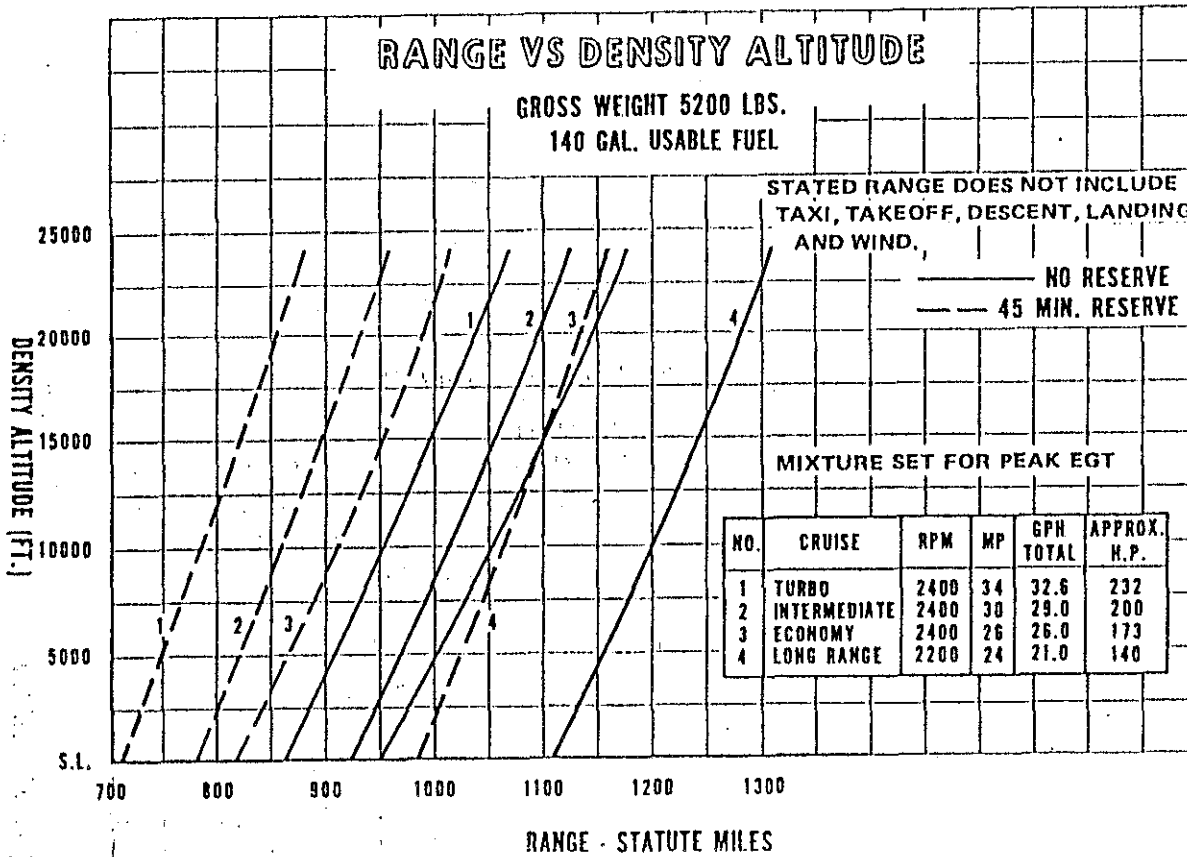

TURBO AZTEC E

AZTEC "E"

# AZTEC E

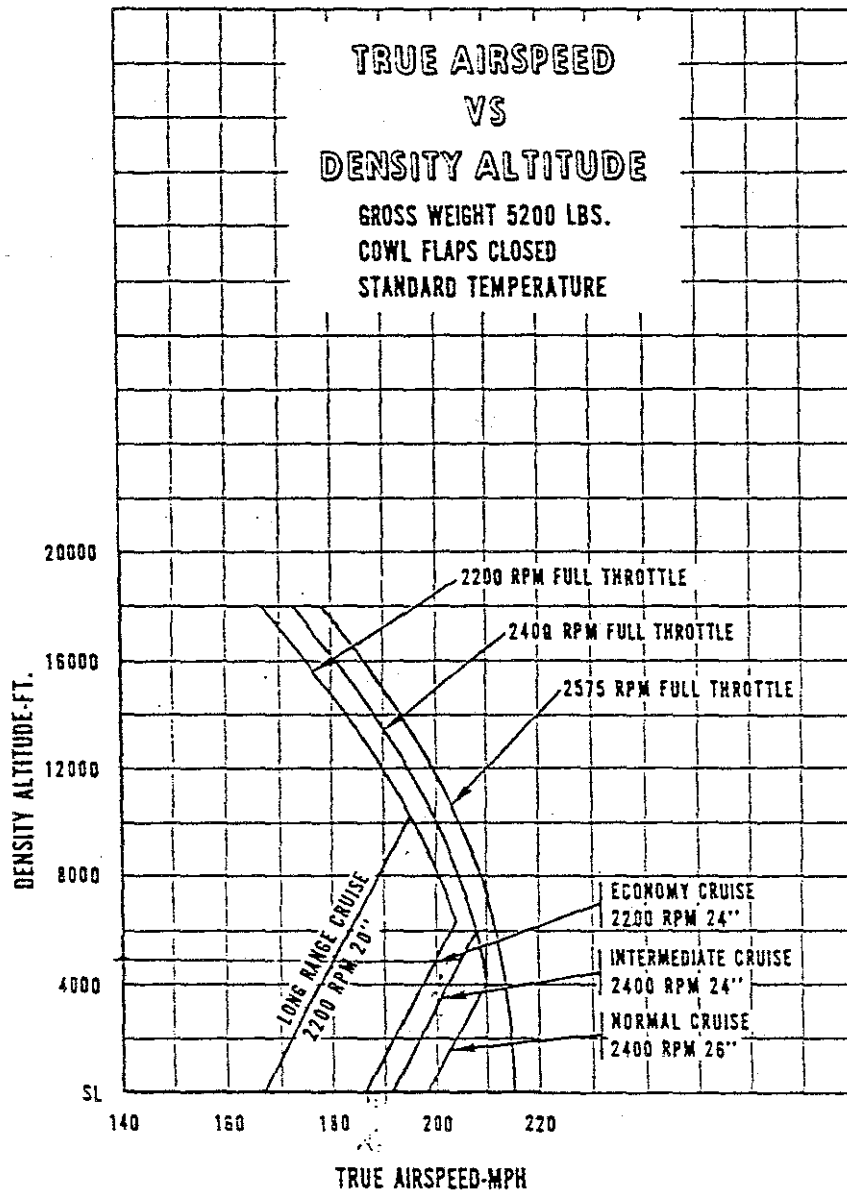



# TURBO AZTEC E

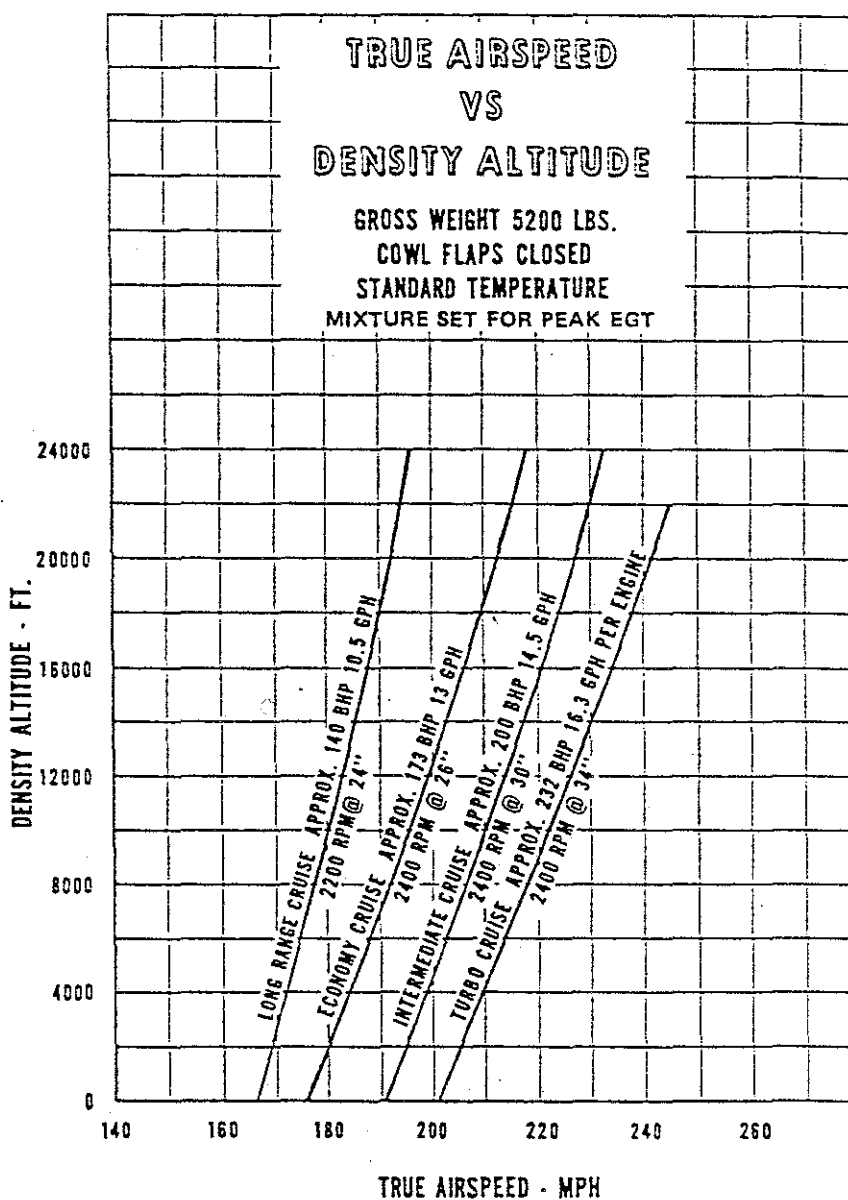

# AZTEC E TURBO AZTEC E

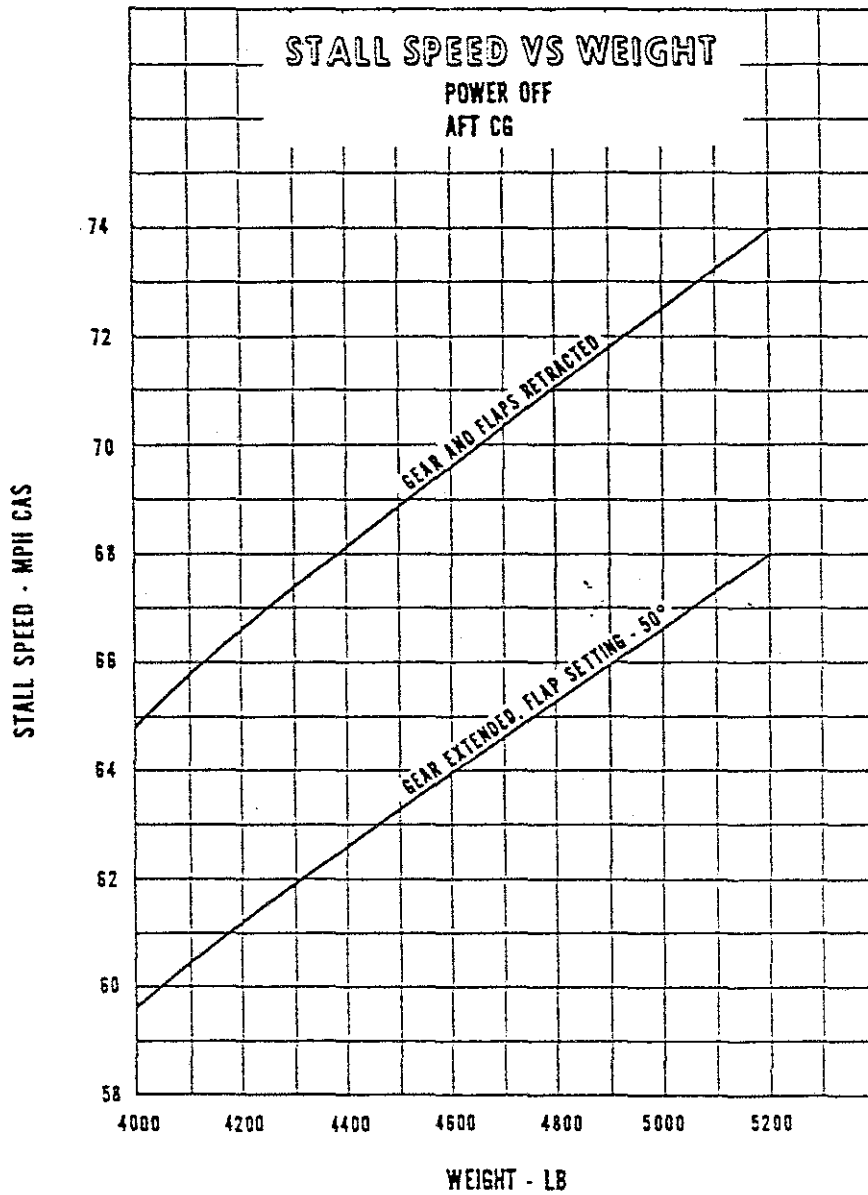

# AZTEC E TURBO AZTEC E

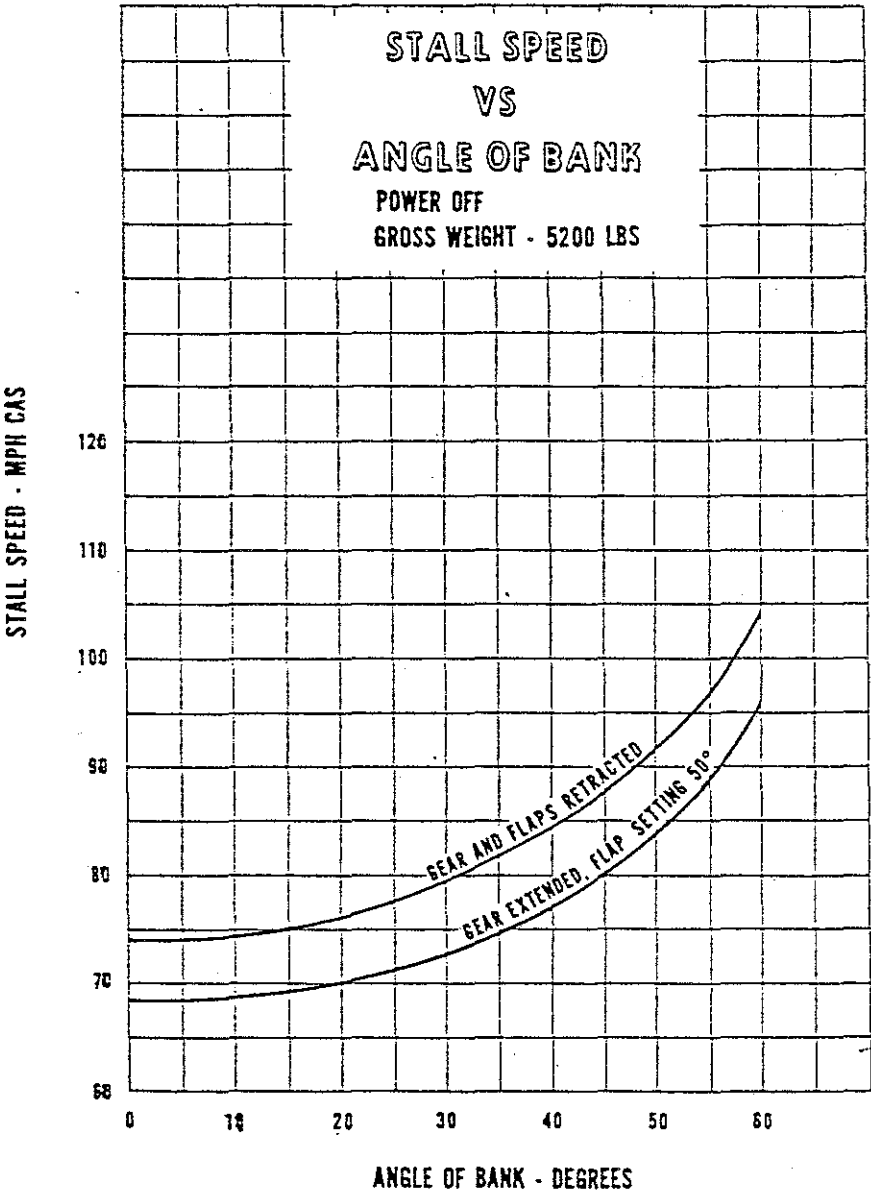

AZTEC "E"

# AZTEC E TURBO AZTEC E

LANDING DISTANCE OVER 50 FEET  
TOUCHDOWN SPEED 68 MPH  
BARRIER SPEED 86 MPH  
PAVED LEVEL DRY RUNWAY  
50° FLAPS

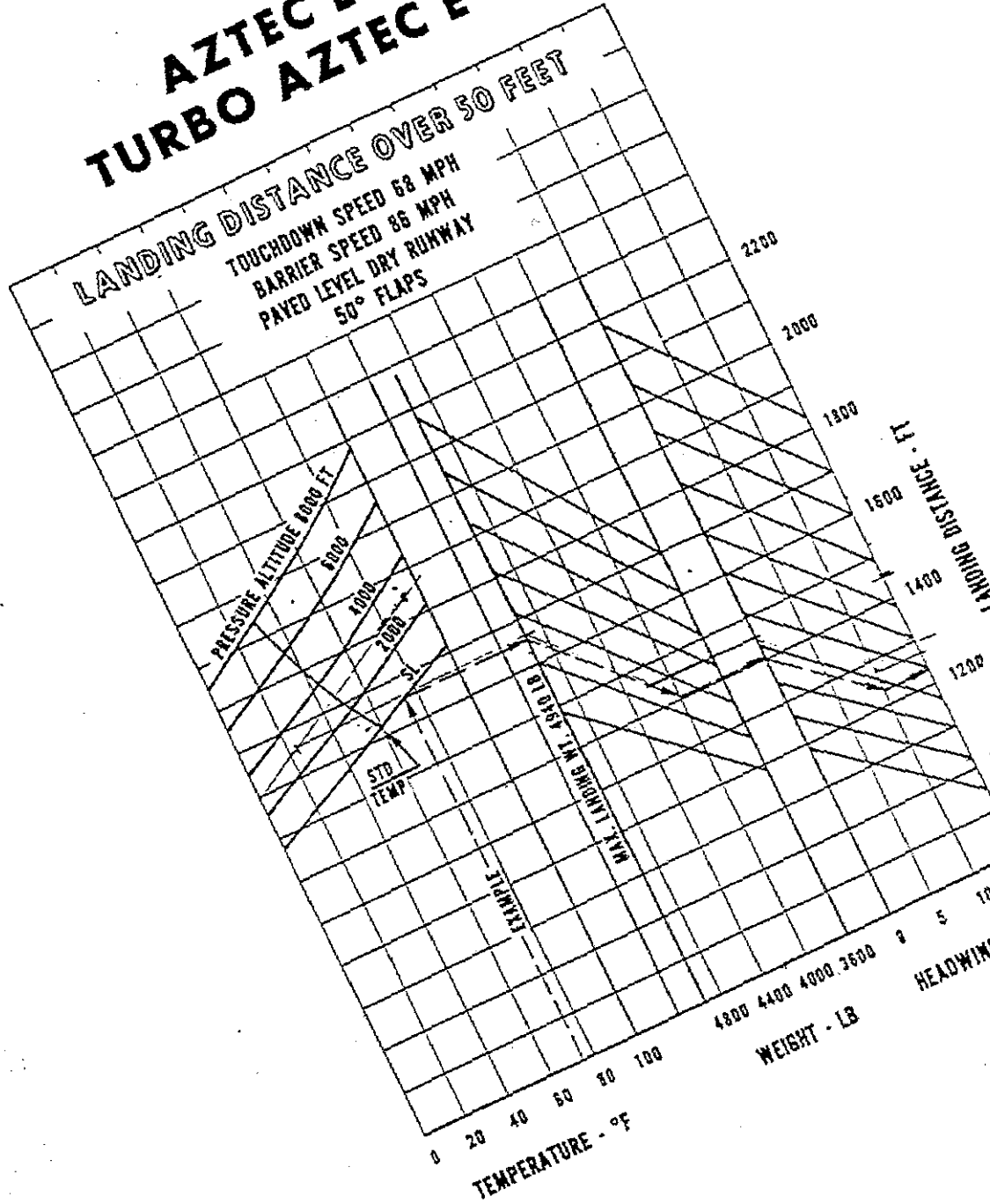

# TURBO-AZTEC E

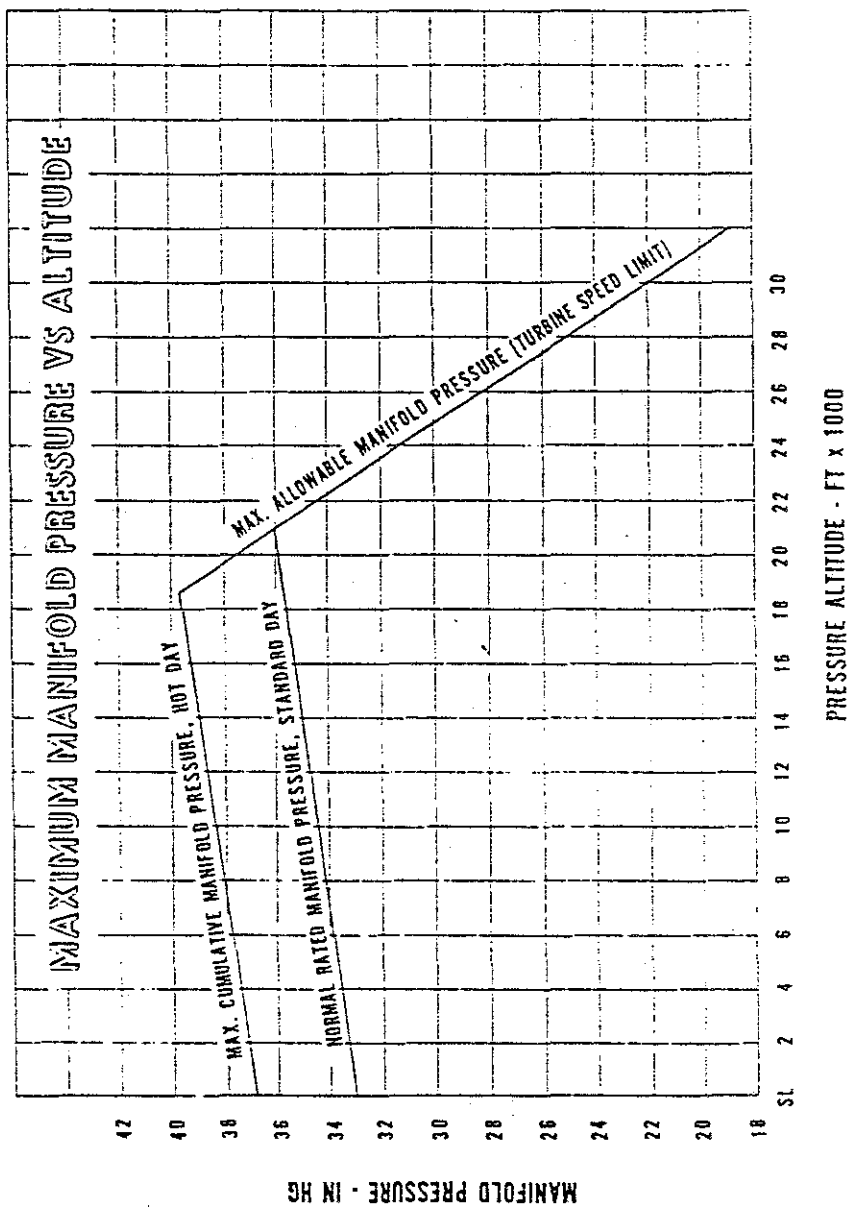

PERFORMANCE CHARTS  
 ISSUED: September 1, 1970  
 REVISED: October 30, 1972

# AZTEC E

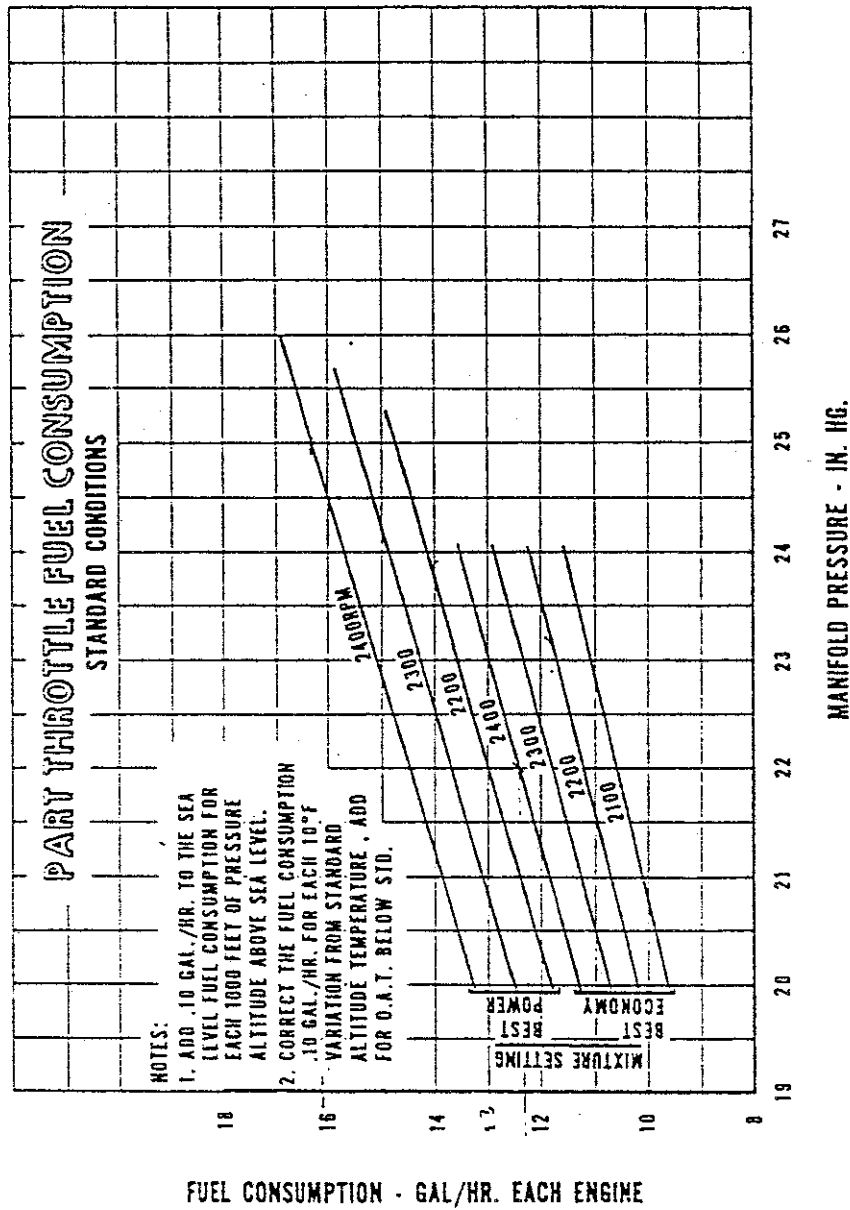

# TURBO AZTEC

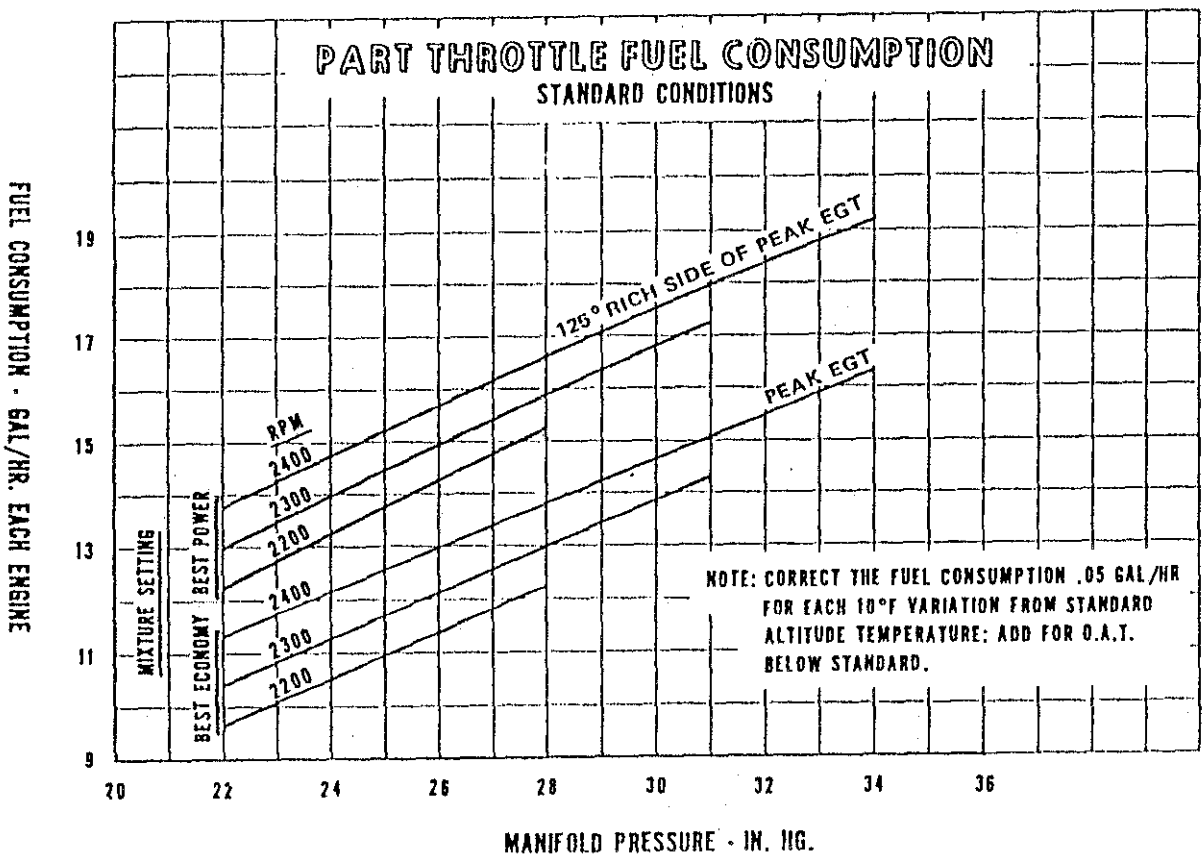

PERFORMANCE CHARTS  
ISSUED: September 1, 1970  
REVISED: October 30, 1972

# AZTEC E TURBO AZTEC E

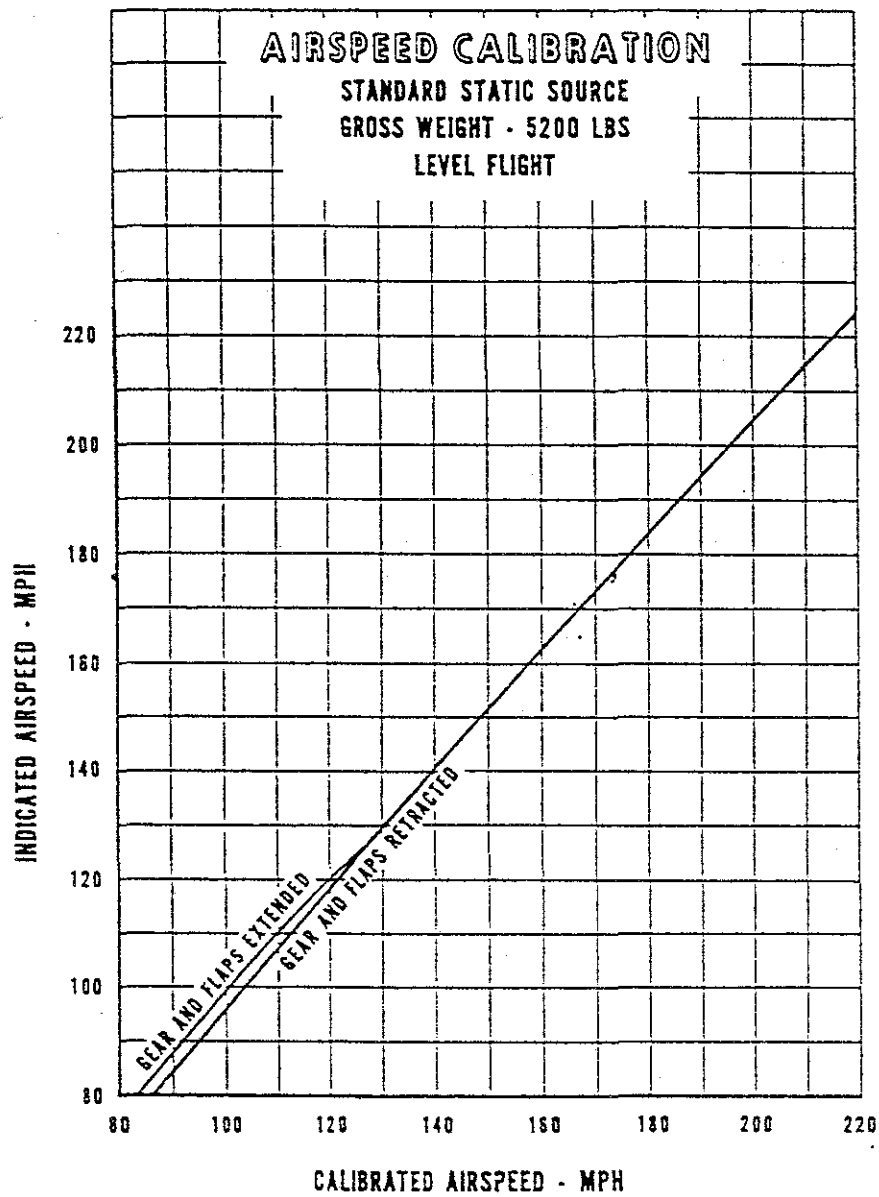



### Power Setting Table (Cruise) - Lycoming Model IO-540-C4B5, 250 HP Engine

Normal Cruise		Intermediate Cruise		Economy Cruise		Long Range Cruise	
Approx 210 HP		Approx 190 HP		Approx 175 HP		Approx 140 HP	
RPM	MP	RPM	MP	RPM	MP	RPM	MP
2400	26.0	2200	26.0	2200	24.0	2100	21.0
		2300	25.0	2300	23.2	2200	20.0
		2400	24.0	2400	22.4	2300	19.3

1. To maintain constant Power, correct manifold pressure approximately 0.17" Hg. for each 10° F variation in induction air temperature from standard altitude temperature. Add manifold pressure for air temperatures above standard; subtract for temperatures below standard.
2. To determine fuel consumption for these power settings refer to the Fuel Consumption Chart.
3. DO NOT EXCEED 27" MANIFOLD PRESSURE BELOW 2300 RPM or 25" BELOW 2000 RPM.

### Power Setting Table (Cruise) - Lycoming Model TIO-540-C1A, 250 HP Engine

Turbo Cruise		Intermediate Cruise		Economy Cruise		Long Range Cruise	
Approx 232 HP		Approx 200 HP		Approx 173 HP		Approx 140 HP	
RPM	MP	RPM	MP	RPM	MP	RPM	MP
2400	34.0	2300	31.0	2200	28.0	2100	25.0
		2400	30.0	2300	27.0	2200	24.0
		2500	29.0	2400	26.0	2300	23.0

1. To maintain constant power, correct manifold pressure approximately 0.17" Hg. for each 10° F variation in induction air temperature from standard altitude temperature. Add manifold pressure for air temperatures above standard; subtract for temperatures below standard. Do not exceed 34.0 MP at 2400 RPM with mixture strengths less than full rich.
2. To determine fuel consumption for these power settings refer to the Fuel Consumption Chart.
3. Do not exceed 39.5" Hg. up to 18,500 feet. Above 18,500 feet the following manifold limits must be observed:

Altitude	M. P.	Altitude	M. P.
20,000 Ft	37.0"	26,000 Ft	28.0"
22,000 Ft	34.0"	28,000 Ft	24.8"
24,000 Ft	31.0"		

NOTES

NOTES